

# P 15 WASH

Operating instructions

Version 1.04

Software  $\geq$  1.0.1



## Content

|  |           |
|--|-----------|
| <b>1. Introduction</b>   | <b>05</b> |
| 1.1 P15 Wash   | 05        |
| 1.2 Important differences between the models HP/HC/WW                        | 05        |
| <b>2. Dimensions</b>   | <b>06</b> |
| <b>3. Product overview</b>   | <b>07</b> |
| <b>4. Safety instructions</b>  | <b>08</b> |
| <b>5. Installation</b>   | <b>10</b> |
| 5.1 Unpacking the device   | 10        |
| 5.2 Connection of the fixture to the power supply                            | 10        |
| 5.3 Mains connection   | 11        |
| 5.4 Wiring the power feed-through  | 11        |
| 5.5 Signal connections   | 12        |
| 5.5.1 DMX cabling  | 12        |
| 5.5.2 Ethernet cabling   | 12        |
| 5.5.3 Wireless reception   | 12        |
| 5.6 Mounting the devices   | 13        |
| <b>6. Control panel</b>  | <b>14</b> |
| 6.1 Menu overview P15 Wash   | 15        |
| 6.2 FACTORY DEFAULTS - Factory settings                                      | 17        |
| 6.3 USER DEFAULTS - User settings  | 17        |
| 6.4 DMX / NET ADDRESS - DMX addressing / Artnet addressing / sACN addressing | 17        |
| 6.5 PERSONALITY - Personal settings  | 18        |
| 6.6 STANDALONE operation   | 21        |
| 6.7 INFO-menu  | 22        |
| 6.8 Shortcuts - quick access   | 22        |
| <b>7. Control options</b>  | <b>23</b> |
| 7.1 DMX  | 23        |
| 7.1.1 Operating modes P15 Wash   | 23        |
| 7.1.2 DMX channel functions P15 Wash   | 25        |
| 7.1.3 Control channel  | 30        |
| 7.1.4 Sparkle effect, sparkle speed  | 30        |
| 7.2 Artnet   | 31        |
| 7.3 Streaming ACN  | 31        |
| 7.4 Wireless-DMX   | 31        |
| 7.5 RDM  | 31        |
| 7.5.1 RDM-UID  | 31        |
| 7.5.2 RDM-PIDs   | 31        |
| 7.5.3 Standard RDM parameter IDs   | 32        |
| 7.5.4 Manufacturer specific RDM parameter IDs                                | 32        |
| 7.5.5 RDM sensor IDs   | 33        |
| <b>8. Service</b>  | <b>33</b> |
| 8.1 Service menu   | 33        |
| 8.2 Software update  | 34        |
| 8.3 Testing of electrical equipment  | 34        |
| 8.4 Optional pan/tilt limitation   | 35        |
| 8.4.1 Installation of the limitation   | 35        |
| 8.4.2 Removal/dismantling of the limitation                                  | 38        |
| 8.5 Cleaning the device  | 39        |
| 8.6 Service and maintenance  | 39        |
| 8.6.1 Inspection of lubricated moving parts                                  | 39        |
| 8.6.2 Checking the plastic parts   | 40        |
| <b>9. Overview of error codes for all fixtures</b>                           | <b>41</b> |
| <b>10. JB-Lighting user network</b>  | <b>42</b> |
| <b>11. Specifications</b>  | <b>43</b> |
| <b>12. EU Declaration of Conformity</b>                                      | <b>44</b> |



## 1. Introduction

### 1.1 P15 Wash

The P15 is available in 3 models. The models differ in the light module and partly in the color filters and in the CTC filters. The differences can be found in the DMX channel functions.

- P15 Wash HP (High Power)
- P15 Wash HC (High CRI)
- P15 Wash WW (Warm white)



**P15** HP

**P15** HC

**P15** WW

| Specification     | HP - High Power                      | HC - High CRI                   | WW - Warm White                 |
|-------------------|--------------------------------------|---------------------------------|---------------------------------|
| Color temperature | 6800 K                               | 5800 K                          | 3200 K                          |
| Luminous flux     | 75.000 lm<br>(34.000 lm Output)      | 54.000 lm<br>(22.000 lm Output) | 44.000 lm<br>(19.000 lm Output) |
| CRI               | 73 +/-3<br>(with CRI filter 90 +/-3) | 92 +/-3                         | 93 +/-3                         |
| Correction filter | linear CTO<br>7000 K to 3200 K       | linear CTO<br>6000 K to 3200 K  | linear CTB<br>3200 K to 7700 K  |

### 1.2 Important differences between the models HP/HC/WW

The differences between the models **High Power / High CRI / Warm White** are as follows:

#### **DMX Channel 26 (43/44)**

color temperature correction: at the **HP** and **HC** model is a **different CTO filter**  
at the **WW** model a **CTB filter**

Detailed information see DMX channel assignment for P15 Wash on page 25.

# P 15 WASH

## 2. Dimensions

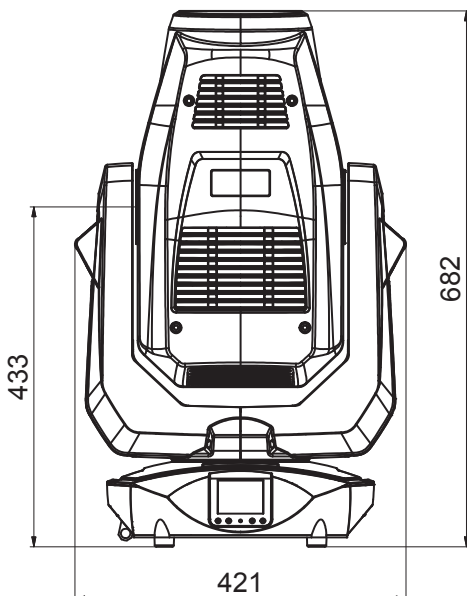
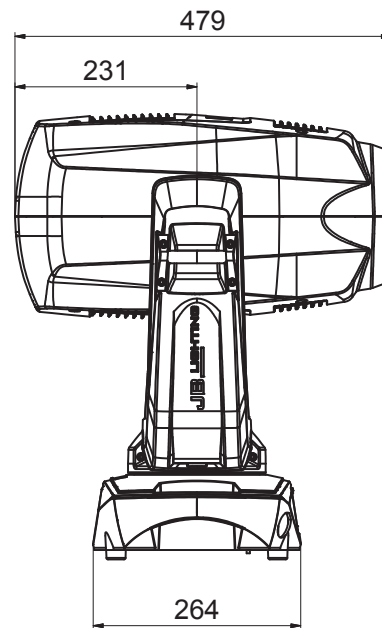
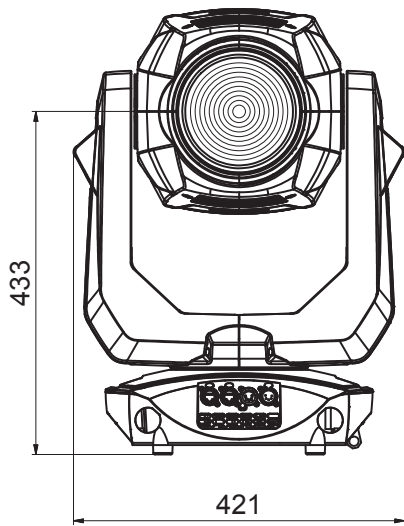
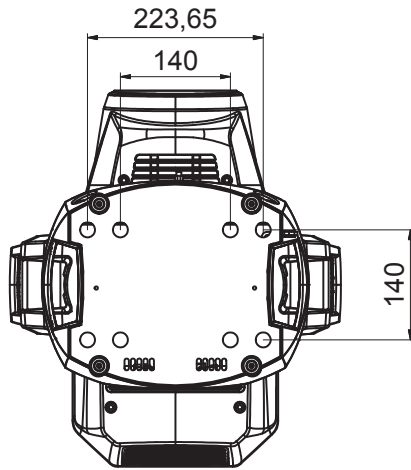

3. Product overview

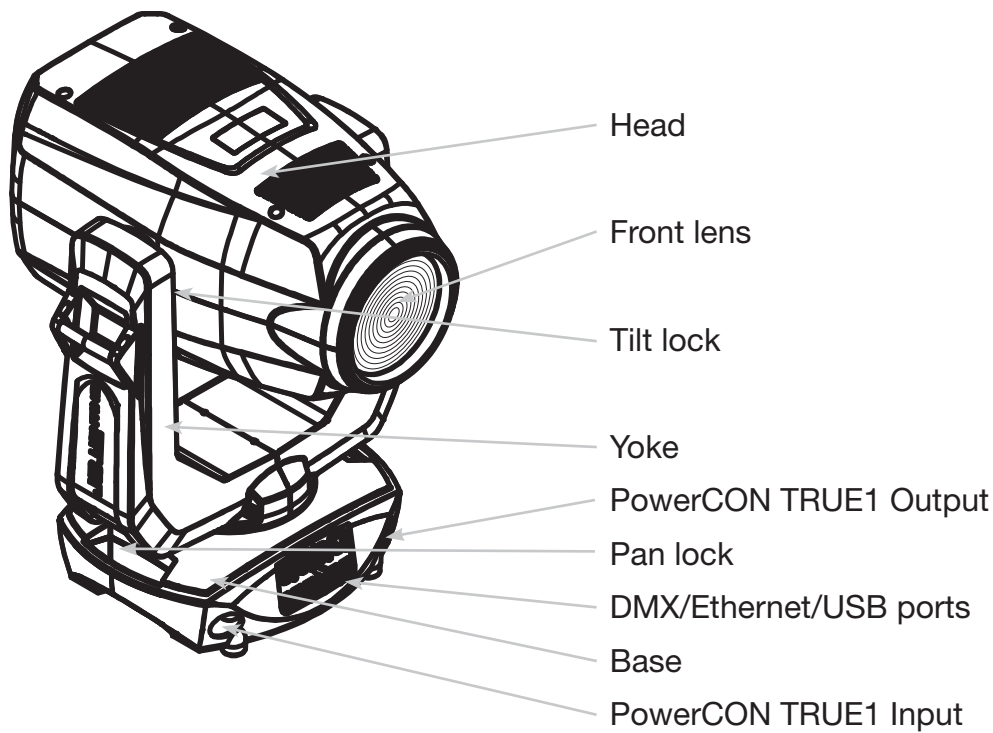
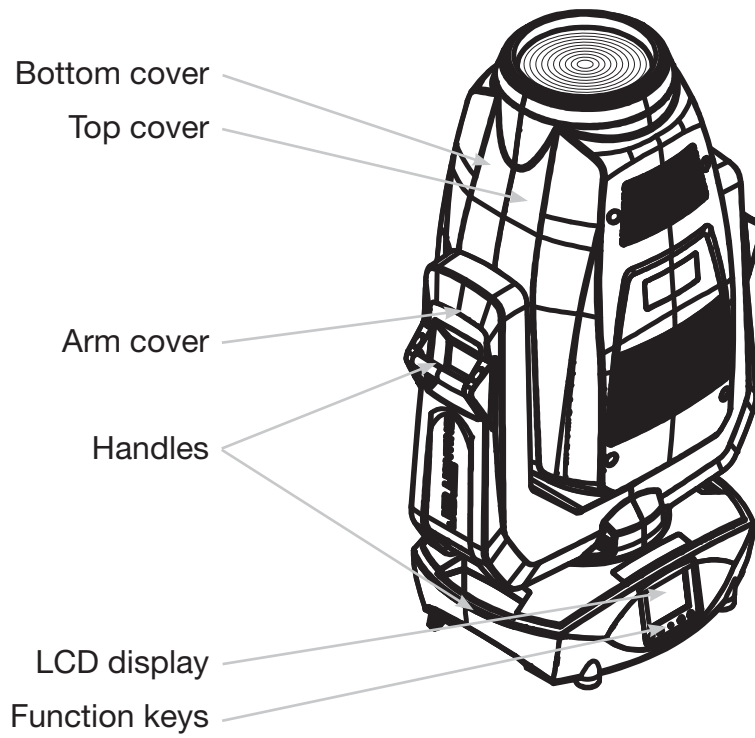

## 4. Safety instructions



**ATTENTION:** For your own safety, please read these operating instructions carefully before first use.

This spotlight has left our company in excellent condition. To maintain this condition and to ensure safe operation, it is absolutely essential to observe the following safety instructions and warnings which are described in this operating manual.

The manufacturer accepts no liability for damage caused to the device by disregard of these operating instructions or unauthorised modifications.

Please note that damage caused by manual modifications to this unit is not covered by the warranty.



**ATTENTION:** This device is only suitable for professional use! Protection class IP 20  
- only for use in dry environments (indoors)!

**ATTENTION:** JB-Lighting Lichtenlagentechnik GmbH does not authorise the use of its devices in life support systems. Life-supporting systems are systems whose purpose is to maintain or stabilise life and whose defect or malfunction may result in death or injury to persons.

The product in this manual complies with the following EU directives:

- Radio Equipment Directive 2014/53/EU (RED)
- Restriction of the use of certain hazardous substances 2011/65/EU (RoHS)



**ATTENTION:** Allow the device to cool down and disconnect the device from the mains before opening the device. Touching live parts (high voltage) can give you an electric shock.

Ensure that the mains voltage to be connected is not higher than that indicated on the type plate. This device should only be operated with the power source indicated on the type plate. If you are not sure what type of power supply you have, contact your dealer or power supplier.

Always disconnect the device from the power supply before carrying out cleaning work or before replacing fuses or parts.

The light source of this luminaire may only be replaced by the manufacturer, a service technician authorized by the manufacturer or a similarly qualified person.

The mains plug must always be accessible after the spotlight has been installed. Do not overload the sockets or extension cables as this could result in fire or electric shock. Do not place any objects on the power cable. Do not install the spotlight in such a way that people can trip over or step on the power cable. Make sure that the power cable can never be crushed or damaged by sharp edges. Check the unit and the power cable from time to time.

Leave maintenance work to a qualified technician!



ATTENTION: This fixture corresponds to protection class I. For this reason, this spotlight must be connected to a mains socket with earthing contact.

Never connect this device to a dimmer pack.

During first use, some smoke and odour may occur. This is normal and does not necessarily mean that the device is defective.

The device becomes hot during operation. Never touch the device with bare hands during operation!

When replacing fuses, only use the same types with identical values! Only have fuse replacement carried out by a qualified technician



ATTENTION: DAMAGE TO EYES! Do not look into the light source for long periods during operation. This can be harmful to the eyes. Attention: potentially hazardous radiation - Risk group 2 based on DIN EN 62471

If the device has been exposed to strong temperature fluctuations (e.g. after transport), the device must not be switched on immediately. The resulting condensation can damage your device. Leave the device switched off until it has reached room temperature.

**If the P15 is operated below 20° some of the functions are reduced in speed. This is a protective mechanism of the P15, as at low temperatures the lubricant is relatively viscous and can therefore cause the effect to be slurred. From indoor temperatures of 21° and upwards, the spotlight runs normally! This temperature is quickly reached under normal operation (LED engine on).**

Do not shake or knock the device. Avoid brute force during installation or operation.

This light was designed for indoor use only. Do not expose this device to rain or moisture.

When choosing a mounting location, make sure that the device is not exposed to extreme heat, moisture or dust.

Ventilation openings and slots in the head and foot of the spotlight are used for ventilation to ensure reliable operation of the device and to protect it from overheating, these openings must not be covered.

Never cover the front lens when the spotlight is in use.

The openings should never be covered with substances or other objects so that the airways are blocked.

This device must not be operated in an environment without adequate ventilation.

The device may only be operated when the housing is closed and all screws/Camlocs are firmly tightened.

The device must always be secured with an additional safety device.

Ensure that the area below the spotlight is clear during installation, alteration and removal.

# P 15 WASH



ATTENTION: The distance between the light emission and the surface to be illuminated must be at least 4,0 meters.



ATTENTION: Allow a fixture distance of at least 1,0 meter from easily flammable material

The maximum ambient temperature of 45°C must not be exceeded.



ATTENTION: The front lens must be replaced if it is visibly damaged to the extent that its function is impaired, e.g. by cracks or deep scratches!

Do not operate the device until you have become familiar with its functions. Prevent operation by persons who are not qualified to use the device. Most damage is the result of improper operation! Please use the original packaging or specially adapted flight cases if the device is to be transported. When using the original packaging, the locks must not be closed!



ATTENTION: To avoid damaging the internal parts of the light head, never let sunlight shine directly into the front lens.

## 5. Installation

### 5.1 Unpacking the device

Contents of the packaging: This spotlight, two Omega brackets with original Camloc fasteners, powerCON-TRUE1 Schuko cable and a safety note. Open the packaging at the top and remove the powerCON TRUE1 cable, the inlay and the safety instructions. The Omega brackets are located under the spotlight. Check the P15 for possible transport damage. This should be communicated immediately to the transport company.

### 5.2 Connection of the fixture to the power supply



The P15 is supplied with an assembled Schuko power cable with the powerCON-TRUE1 plug (only the powerCON-TRUE1 plug is included in the US version). The connection of the P15 to the power supply (100-240 volts, 50 - 60 hertz) must comply with the connection rules of the respective country.

Connection in Germany/Europe:

| Wire colour  | Function         | Symbol |
|--------------|------------------|--------|
| Brown        | Phase            | “L”    |
| Blue         | Neutral wire     | “N”    |
| Green/Yellow | Protective earth | “PE”   |

## Connection outside Europe:

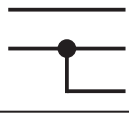
The P15 may only be operated on the following power supply systems:

|                   | Mains   |   | P15          |
|-------------------|---|---|--------------|
| 2 wires, 1 phase  | L<br>N  |  | L<br>N<br>PE |
| 3 wires, 1 phase  | L<br>N<br>L   |  | L<br>N       |
| 4 wires, 3 phases | L <sub>1</sub><br>L <sub>2</sub><br>L <sub>3</sub><br>N |  | L<br>N<br>PE |

### 5.3 Mains connection

Connected loads: Voltage 100-240 V, frequency 50 - 60 Hz, power max. 1100 VA

The electrical safety and function of the device can only be guaranteed if it is connected to a properly installed protective conductor system. It is very important that this basic safety requirement is met. If in doubt, have the electrical installation checked by a specialist. The manufacturer cannot be held responsible for damage caused by a missing or interrupted protective conductor (e.g. electric shock)! Only use the device when it is completely assembled so that no electrical components can be touched. **(Danger 100-240 V)**

If you have observed the listed points, you can plug in the devices or have them connected to the mains by a specialist.



ATTENTION: The P15 can light up immediately if standalone operation is activated or a DMX signal is present!

### 5.4 Wiring the power feed-through



ATTENTION: Only have it carried out by a specialist!

The P15 has a powerCON-TRUE1 out power output. Depending on the local conditions several devices can be linked by powerCON-TRUE1 in and powerCON-TRUE1 out. Connect a maximum of three (when using 230V/16A) P15's in a row.

Use an approved three-core cable with a cross-section of at least 1.5 mm<sup>2</sup>. Cabling must be done with the original Neutrik coded plugs. The installation instructions of the manufacturer ([www.neutrik.com](http://www.neutrik.com)) and the colour coding of the cable must be observed.

| Wire colour  | Function         | Symbol   |
|--------------|------------------|--|
| Brown        | Phase            | “L”  |
| Blue         | Neutral wire     | “N”  |
| Green/Yellow | Protective earth | “PE”  |

## 5.5 Signal connections

### 5.5.1 DMX cabling

The DMX cabling (signal lines) should be done with a 4-pin cable with shielding. We recommend a DMX cable (110 Ohm, 2x0.22mm<sup>2</sup> or 4x0.22mm<sup>2</sup>). The plugs and sockets are 5-pin XLR connectors, which can be purchased in specialist shops.

#### Pin assignment:

Pin1 = Ground/Shielding

Pin2 = DMX -

Pin3 = DMX +

Pin4 = not connected

Pin5 = not connected

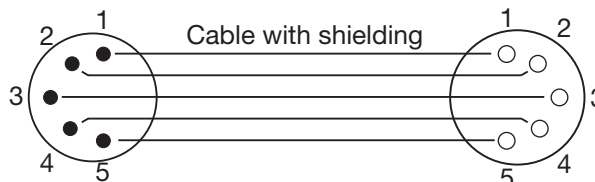

The P15 has a DMX-in and DMX-out connector. Now connect the DMX output of your controller to the 1st P15 (Controller DMX-Out -> P15 DMX-In). Then the 1st P15 with the 2nd P15 (P15 DMX-Out -> P15 DMX-In) and so on. In some cases it is advisable to insert a so-called end connector (XLR connector with a 120 Ohm resistor between pin 2 and pin 3). Whether an end connector is required depends on various factors, including the cable lengths used and the number of devices. However, as long as no problems occur in the DMX line, this is not necessary.

### 5.5.2 Ethernet cabling

Ethernet cabling can be done with standard network lines. The sockets on the device are Neutrik etherCON sockets. Special cables with etherCON connectors are recommended by Neutrik. The two sockets on the P15 are connected to each other via a switch. Up to 10 devices can be connected in series without any delay. Of course, the spotlights can also be supplied in a star configuration via an external switch. The received signal can be output via DMX. To do this, set the DMX OUTPUT CONFIG setting to ON in the PERSONALITY menu. After confirming with ENTER, the spotlight emits the entire universe received via DMX.



ATTENTION: Make sure that there is no signal at the DMX input at the same time !!

### 5.5.3 Wireless reception

The P15 is equipped as standard with a **LumenRadio** CRMX receiver for wireless DMX. The receiver can process both DMX and RDM. If a cable and wireless connection are connected to the P15, the cable connection has priority! The received signal can be output via DMX. To do this, set the DMX OUTPUT CONFIG setting to ON in the PERSONALITY menu. After confirming with ENTER, the spotlight emits the entire universe received via DMX.



ATTENTION: Make sure that there is no signal at the DMX input at the same time !!

## 5.6 Mounting the devices



**ATTENTION:** The distance between the light emission and the surface to be illuminated must be at least 4,0 meters.



**ATTENTION:** Allow a fixture distance of at least 1,0 meter from easily flammable material

The P15 can be placed on the floor or hang on a trussing system. **A mounting horizontally to a truss system like in the picture is only with our special Camlock plate allowed (see picture).**

When placing the unit on the floor make sure that it stands on rigid ground, because the air inlets in the base must not be covered with anything!

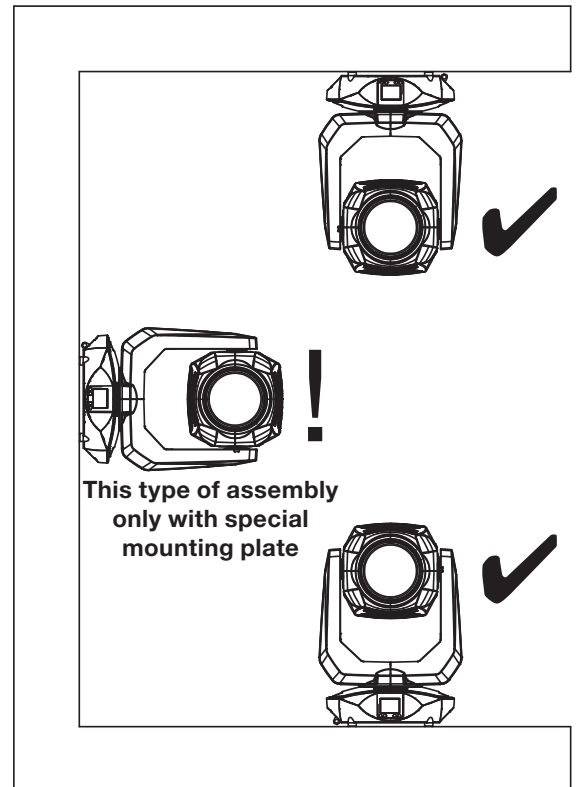

To mount the unit on a trussing system use two of the original JB-Lighting omega brackets with original Camloc-connectors. You have following four possibilities to mount the omega brackets.

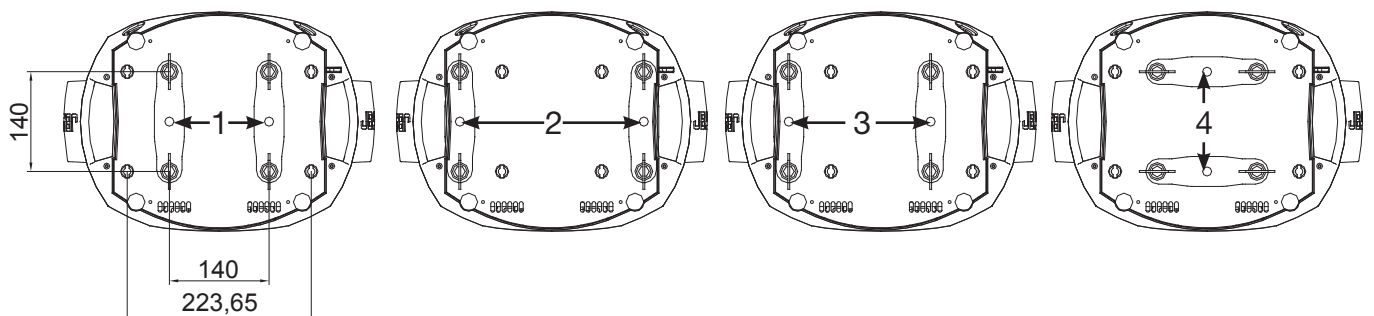

The Camlocs must snap in to be locked properly. Ensure that the structure (for example a truss system ) to which you are attaching the fixture is secure. If you install the fixture to a hanging system (for example to a truss system) always attach a safety cable, that can hold at least 10 times the weight of the fixture. There is a corresponding eyelet on the fixture for the secondary safety device (see picture).



eyelet for the secondary safety device

## 6. Control panel

The P15 has a graphic colour display that can be rotated 180° when installed in a suspended position. The display can be rotated in the PERSONALITY MENU or via shortcut ENTER + UP in the main screen.

All parameters of the P15 can be set on the control panel (see menu overview page 15).

### Function and operation of the display

The main menu provides information regarding the set DMX mode and, when the wireless mode is switched on, the field strength of the associated transmitter module. "ENTER" calls up a sub-menu or confirms an input. "ESC" is used to exit a function or a menu item. "UP" and "DOWN" are used to navigate within the menu and to enter values.



Special areas can only be called up using a specific key combination. To do this, press and hold the "ENTER" key and then use the opposite "ESC" key to access the menu. To exit the function, proceed in reverse order.

This applies in the SERVICE area for the FINE ADJUST function and in the STANDALONE area for the MODIFY, RUN and REMOTE functions.

The main menu can also be locked to prevent unintentional access. It is also locked by pressing the "ENTER" key (keep it pressed) and then additionally locking it with the opposite "ESC" key.

### Display illumination as function display

The display illumination remains switched off during the reset. Slowly flashing display illumination when "JB-Lighting" is displayed means no DMX signal is present.

A rapidly flashing display illumination when "JB-Lighting" is displayed means that a new error has been stored in the "ERROR LIST", also an error message in the display (e.g. \*PAN TIMEOUT) indicates this current error. This error occurs during this reset or in the operation. This error is now automatically set to "read", but remains in the "ERROR LIST". Only when the error has been deleted from the ERROR LIST does the P15 start again without error signalling.

If errors occur again and again contact the dealer / distributor or our service department.

If the P15 receives a DMX signal, the display illumination goes out after a short time.

Further settings for the display illumination see page 20 - BACKLIGHT MODE.

### DMX addressing

In the main menu, the DMX address can be set directly by pressing the up/down keys.

## Display operation via battery backup

By pressing the left button below the display, the configuration battery operation of the headlamp is activated, so the headlamp can be configured without power. It is possible to configure all the settings displayed by the menu, for example the DMX address can be set.

### 6.1 Menu overview P15 Wash

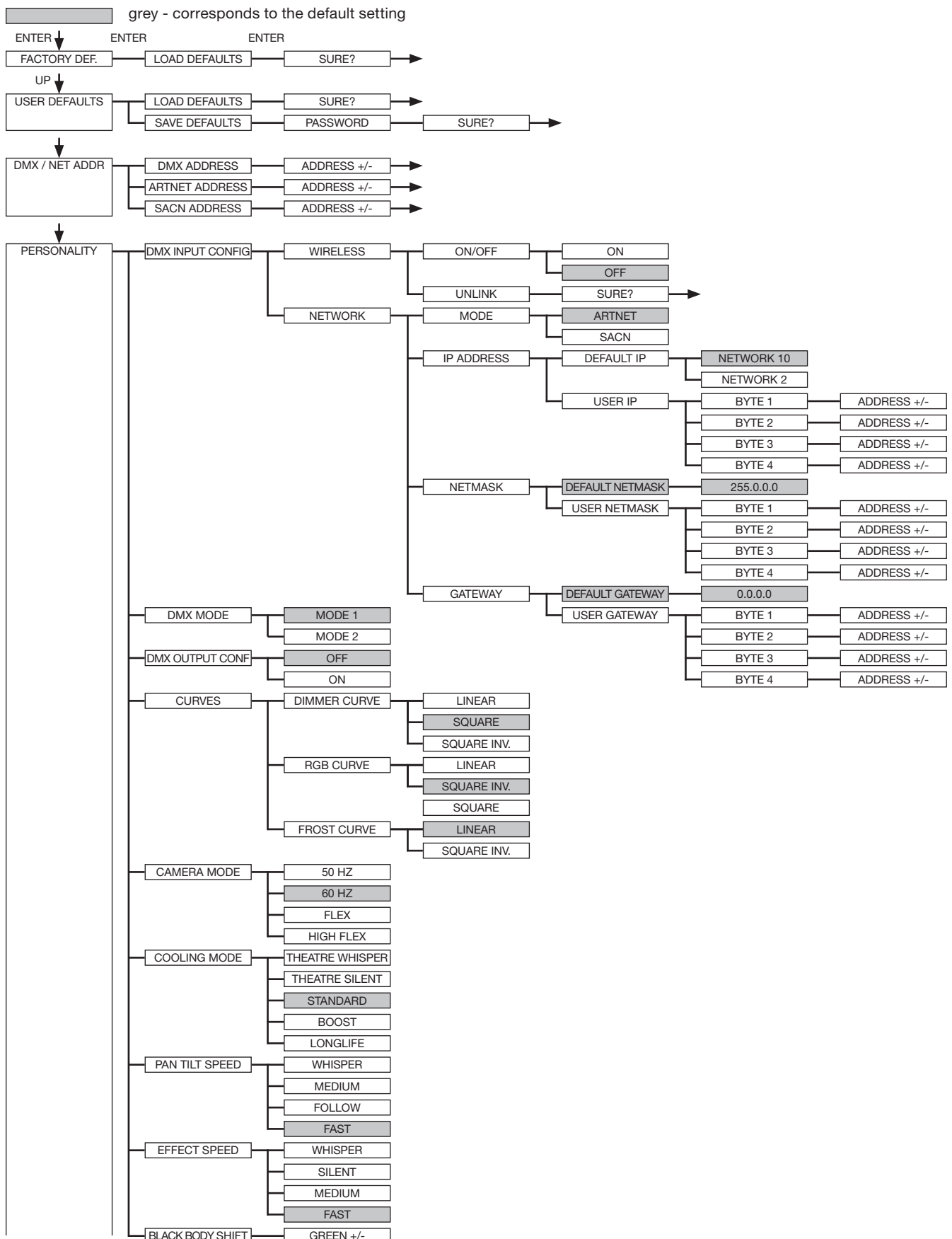

# P 15 WASH

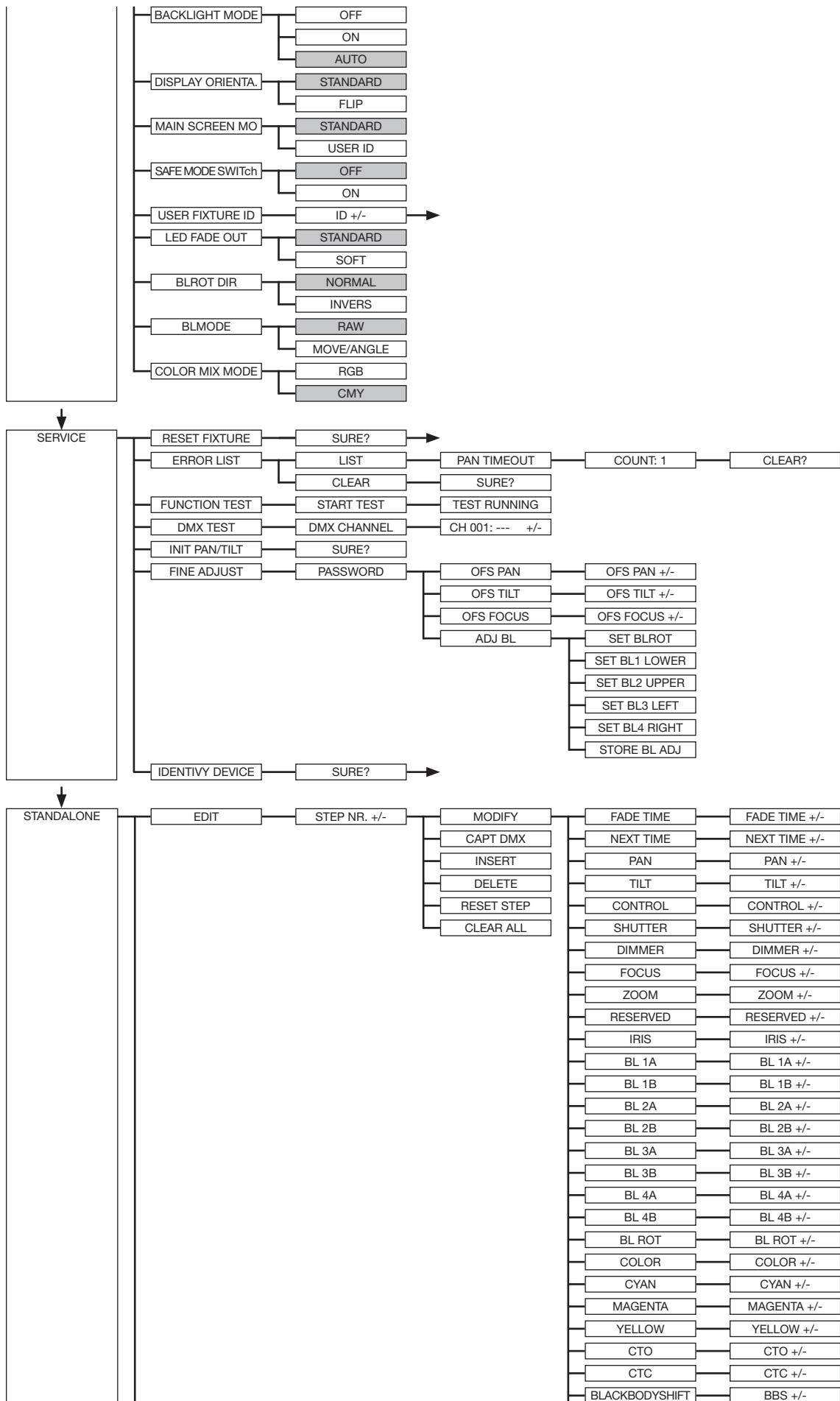

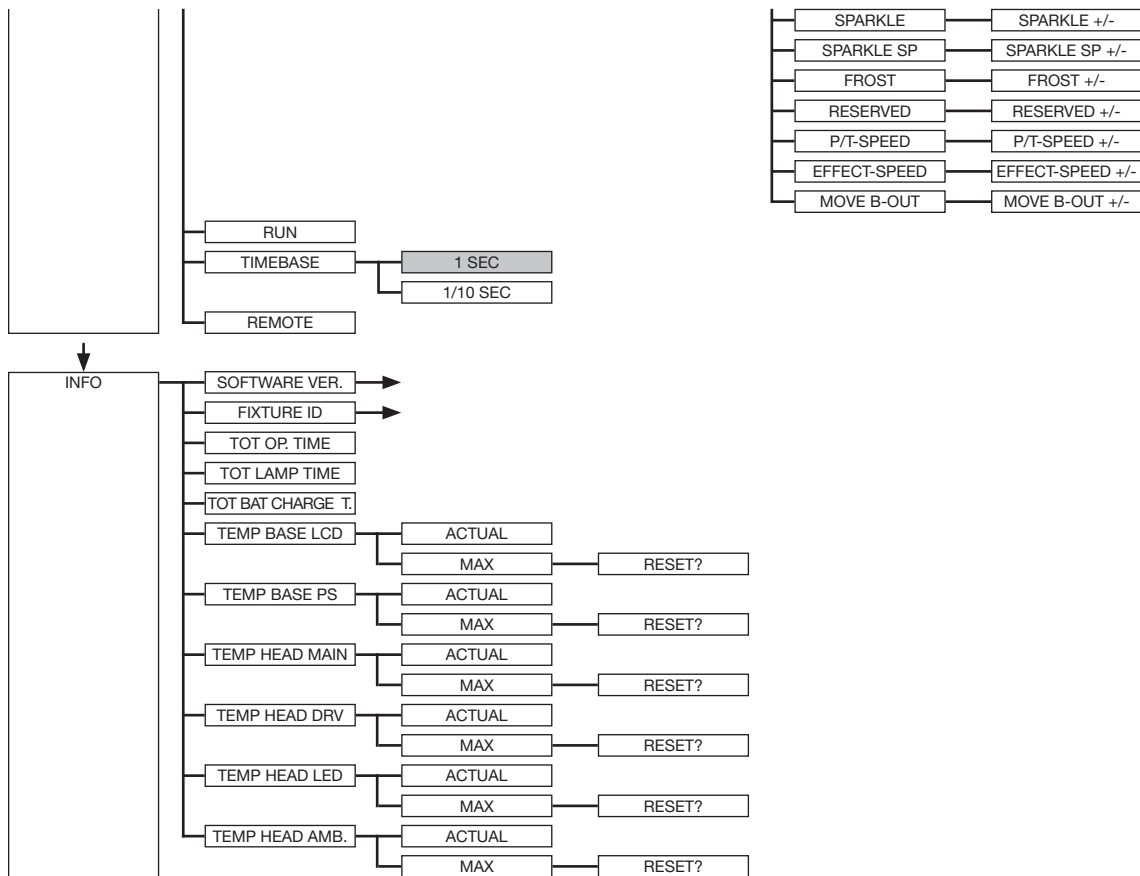

## 6.2 FACTORY DEFAULTS - Factory settings

To reset the P15 Wash to factory settings, go to the menu item FACTORY DEFAULTS, LOAD DEFAULTS. After confirming the security query SURE? by pressing the "ENTER" button for 2 seconds, all parameters are reset to the factory settings.

## 6.3 USER DEFAULTS - User settings

If the user has set the P15 in the PERSONALITY menu to their personal settings, these can be saved and loaded in the USER DEFAULTS menu. In order to prevent unintentional alteration of the data, you must enter the following password during the saving process: Buttons "ESC DOWN UP ENTER"

## 6.4 DMX / NET ADDRESS - DMX addressing / Artnet addressing / sACN addressing

The DMX addressing can be done either directly in the display. Press the "UP" or "DOWN" button to set the desired DMX address. The value is confirmed with the "ENTER" key. However, the DMX addressing can also be done within the menu item DMX / NET ADDR, and there under DMX ADDRESS.

To set the Artnet address, the menu item ARTNET ADDRESS must be selected in the DMX / NET ADDR menu. The Artnet address can now be set using the UP / DOWN buttons. The Artnet address is displayed in the form 000.00.00. This display corresponds to: Net.Subnet.Universum. The sACN address can then be selected in the DMX / NET ADDR -> sACN ADDRESS menu. The address can now be set using the UP / DOWN buttons. The sACN address is displayed in the form 00000.

## 6.5 PERSONALITY - Personal settings

### DMX INPUT CONFIG

In this menu item the options WIRELESS and NETWORK are available.

Under WIRELESS -> ON / OFF the factory-installed radio DMX receiver module of Lumen-Radio can be activated or deactivated and via WIRELESS -> UNLINK the connection to the connected transmitter can be deleted. In order to connect the fixture to a transmitter, wireless must be set to ON on the fixture and the connection button must be pressed briefly on the transmitter. The transmitter is now looking for all fixtures where wireless is enabled and fixtures that are not connected to a transmitter. If the P15 has successfully connected to the transmitter, the display shows a level indication of the current reception quality. If the P15 is additionally connected via the DMX / etherCON connection sockets, these signals have priority over the radio link. Using the key shortcut ESC and DOWN, pressed in the main menu, the headlamp can be booked out of the booked transmitter (see page 22).

Under NETWORK -> MODE you can toggle between Artnet operation and sACN operation. For network operation, the IP address of the spotlight must be selected or set under NETWORK -> IP ADDRESS. Each headlight has a unique standard IP address.

Under IP ADDRESS -> DEFAULT IP this can be changed from the network 10.xxx.xxx.xxx to a network 2.xxx.xxx.xxx. For your own self-definable IP address, you can set your own desired IP address under IP ADDRESS -> USER-IP. This address is divided into BYTE1 to BYTE 4 and can be set one after the other.

### DMX MODE - setting the operation mode

The P15 has 2 operating modes (see channel assignment for P15 Wash on page 25). All parameters of P15 can be operated via mode 1. However, all channels (except pan/tilt) are controlled with 8 bits. By selecting Mode 2 - 16 Bit the gobo, prism rotation, CMY/CTO(CTB), dimmer, focus, zoom, the complete shutter slide unit as well as pan/tilt are controlled via 16 Bit.

### DMX OUTPUT CONFIG - configuration of the DMX output

Under this menu item, the DMX output of the headlamp can be activated, that is a received Art-net, or wireless DMX signal can be output by activating this menu item -> ON via the DMX socket again. Make sure that there is no signal at the DMX input at the same time !!

### CURVES - setting dimmer, RGB/CMY, frost curve

#### Dimmer curve:

The dimmer curve can be changed from SQUARE to LINEAR and to SQUARE INV.. The "exponential" dimmer curve (factory setting) causes the dimmer to fade in and out more smoothly.

#### RGB/CMY curve:

Three different curves can be set for the RGB/CMY curve: LINEAR, SQUARE INV. and SQUARE. LINEAR allows the color to be introduced linearly. With SQUARE INV. the introduction appears optically linear.

#### Frost curve:

The frost curves can be changed from linear to invers exponential (square inv.). The "invers exponential" frost curve causes the frost to fade in and out more smoothly.

## **CAMERA MODE - setting the repetition frequency of the LEDs**

To avoid flickering during TV recordings, the P15 can be adjusted from 50 HZ (PAL, Secam, repetition rate 100Hz) to 60 HZ (NTSC, repetition rate 100Hz) for different camera systems. Flex mode (repetition rate 600Hz) is set when using different camera systems or when shooting with mobile phone cameras or similar non-professional cameras. A HighFlex mode is also available. In this mode, the repetition frequencies are set to 3 kHz, which is necessary to ensure smooth movements in dimmed lighting scenes. The factory setting of the P15 is 60 Hertz. The changeover is also possible with the light mixing console via the control channel.

## **COOLING MODE - adjustment of brightness and fan volume**

In the COOLING MODE menu item you can set the fan control and the brightness of the P15. The following settings are available.

THEATRE WHISPER: Brightness 23600lm (model HP), volume 29dB(a). In this mode, the spotlight runs at the same brightness up to an ambient temperature of 40°C. It is not necessary to speed up the fans in this mode.

THEATRE SILENT: Brightness 27200lm (model HP), from 40°C ambient temperature the spotlight regulates the fans a little up thus remains that the brightness is always the same level.

STANDARD: Brightness 32400lm (model HP), from an ambient temperature of approx. 36°C the fans run to cool the LED accordingly. The brightness remains constant.

BOOST: Brightness 34000lm (model HP), the fans run a little stronger in this mode, from approx. 40° ambient temperature the fans run again accordingly.

LONGLIFE: Brightness 27200lm (model HP), the fans run a little stronger in this mode, from approx. 40° ambient temperature the fans run again accordingly. We would recommend this mode for permanent installations, as the LED module runs cooler and thus more “stress-free”.

There is no danger to the life of the device in any mode, as the P15 has a temperature safety shutdown. In addition, the LED module is switched off from an ambient temperature of 60°C!

## **PAN TILT SPEED - setting pan/tilt speed**

In the PAN TILT SPEED menu you can set the maximum speed, the acceleration and thus also the movement volume of the P15. The following setting options are available.

WHISPER: The speed of Pan / Tilt is reduced so much that a volume of 29dB (A) is not exceeded.

MEDIUM: The acceleration and deceleration ramps are set very soft so that the headlamp brakes softly and starts.

FOLLOW: The positioning and speed of pan/tilt are specially adapted to various follow systems.

FAST: The acceleration and deceleration ramps are set very hard so that the headlamp moves very fast and directly at maximum speed.

## **EFFECT SPEED - setting effect speed**

In the menu item EFFECT SPEED you can set the maximum speed, the effects and thus also the volume of the effects of the P15. The following setting options are available.

WHISPER: The speed of the effects is reduced so much that a volume of 29dB (A) is not exceeded.

SILENT: The speed of the effects is slightly faster and thus a bit louder than with the Whisper setting.

MEDIUM: The acceleration and deceleration ramps of the effects are set very soft, so that the effects are very soft and thus cause little noise.

FAST: The acceleration and deceleration ramp effects are set to maximum speed. Very fast gobo and color changes are possible!

## **BLACK BODY SHIFT - Adjusting the green/magenta balance (+-Green)**

With this option, the white point can be shifted towards green or magenta. With this option, the M18 Profile can be adapted to "old" headlights with a green/magenta shift.

## **BACKLIGHT MODE - setting the display backlight**

This menu item controls the backlight of the display.

OFF: The backlight of the display is always off. The lighting only switches on when a button is pressed. Errors that are indicated by flashing are not displayed in this mode.

ON: The backlight of the display is always on.

AUTO: The backlight is switched on / off due to the action.

## **DISPLAY ORIENTATION - setting the display orientation**

This menu item turns the display orientation. The display can also be rotated when the shortcut ENTER and UP is pressed in the main screen.

## **MAIN SCREEN MODE - view of the main screen**

With this menu item the display of the main screen can be changed. Either the standard (STANDARD) screen is displayed with DMX address and DMX mode or the USER FIXTURE ID. This ID is used to number the headlights and to display this number in the display.

## **SAFE MODE SWITCH - setting of the safe mode switch**

This setting locks the control channel "ON" or enables it "OFF" to activate the control channel's functions for DMX. SAFE MODE SWITCH default set to off.

To temporarily enable individual functions of the control channel, the dimmer and shutter must be set to DMX 000 for the COOLING MODE function.

To activate the remaining functions, simply send either DMX 010 (3.92%) or DMX 239 (93.73%) to the shutter channel.

## **USER FIXTURE ID - adjustment of the user fixture ID**

Used to set the USER FIXTURE ID (0-65535). This can be displayed via MAIN SCREEN MODE and serves as an info display of the headlight number.

## **LED FADE OUT - type of dimming**

Used to set how to dim the lower range from 0-5%.

STANDARD: When dimming the headlamp, all LED's dim out at the same time.

SOFT: When the headlamp is dimmed, the LED's are dimmed out in groups (in a row) one row after the other.

## **BLMODE - Type of shutter control**

Serves to switch the shutter control. With the RAW setting, the two motors of the individual apertures are controlled separately via DMX. With the MOVE/ANGLE setting, one channel is used as a movement channel and the angle of the individual aperture is set via the second channel. A special MA fixture for the MOVE/ANGLE mode is available for download on our homepage.

## **BLROT DIR - Switching the direction of the shutter rotation**

This setting is used to switch the direction of the shutter rotation. To adapt the direction of rotation to other headlights, the direction can be rotated here.

## **COLOR MIX MODE - selection of color mixing RGB or CMY**

Select whether the color mixing of the fixture works via RGB or via CMY

## **6.6 STANDALONE operation**

In standalone operation, up to 10 program steps can be stored in the P15, which can then run in an endless loop. The images can be saved in two ways. Either you program the desired DMX values directly on P15 and save them, or you set the DMX values via a connected DMX console and then store them in the P15.

The menu items MODIFY, RUN and REMOTE can only be called up using a specific key combination. To do this, press and hold "ENTER", and also press "ESC". Before activating these menu items, remove all other devices in the DMX line that send DMX, e.g. consoles or other spotlights that are not configured as slave devices, as otherwise damage to the DMX drivers may occur.

### **Programming the standalone programme on the spotlight display:**

Call up the STANDALONE, EDIT menu item. In the STEP NR+/- menu item, select the desired step and you can change it and its channel parameters in the following menu items: In the MODIFY menu item, set the desired lighting scene and position and determine the individual sequence times of the steps with FADE TIME and NEXT TIME (time for the complete step).

Use INSERT to insert an additional programming step. The DMX values of the previous step are copied to the new step.

Use DELETE to delete a step. The display shows STEP NR: 1/X. Use the selection keys to move to the desired step.

With RESET STEP you reset one step to its default values (DMX 000). The display shows STEP NR: 1/X. Use the selection keys to select your step. CLEAR ALL resets the complete standalone programming steps. Under MODIFY you will find STEP1/1 again. In the STANDALONE, TIMEBASE menu item you have the possibility to change the Fade Time and Next Time from 1 second to 1/10 second.

### **Accept the DMX values from an external console:**

To accept the DMX values of a connected console, you must first enable the Capture DMX input. To do this, go to the CAPT DMX menu item. The display now shows CAPTURE DMX 01/01, press the Enter key to switch to START CAPTURE. Now the P15 reacts to the signals from the external console.

### **Launch the standalone program:**

Call up the STANDALONE menu and navigate to the RUN submenu. Confirm the selection by pressing the key combination "ENTER" (press and hold) and simultaneously "ESC". The display then shows: S-ALONE: 01/XX and the program runs in an endless loop.

Deactivation: Press and hold the "ESC" key and then also press "ENTER". The menu jumps back one level and RUN appears in the display.

## **Operation via master-slave function:**

Connect the P15 Profile via DMX lines and activate the REMOTE menu item for all slave devices. To do this, navigate in the STANDALONE menu to the REMOTE sub-menu. Activate the REMOTE function by pressing and holding "ENTER", and also pressing "ESC". The spotlight is in slave mode when the display shows the status REMOTE INACTIVE or REMOTE ACTIVE.

REMOTE INACTIVE: The P15 Profile is in slave mode but does not receive a DMX signal.

REMOTE ACTIVE: The P15 Profile is in slave mode and receives a DMX signal.

The master device is programmed via the MODIFY menu item and started via RUN (press and hold "ENTER" and also press "ESC").

## **6.7 INFO-menu**

The Info menu informs you about the respective software, the fixture id, about the total operating time and the different temperatures of the spotlight. The first two menu items in the Info area are the software version and the fixture ID, whereby the software version is an important source of information for our service requests, the fixture ID is less important source of internal information. Under the menu item TOT OPERATE TIME the complete operating time of the headlight is displayed. The menu item TOT LAMP TIME provides information about the pure operating time of the LED module. TOT BAT CHARGE TIME shows the complete charging time of the battery (battery backup). The TOT OPERATE TIME and the TOT BAT CHARGE TIME can not be deleted! The following temperatures are also displayed:

**TEMP BASE LCD**, the temperature on the display board

**TEMP BASE PS**, the temperature of the power supply unit

**TEMP HEAD MAIN**, the temperature of the head board

**TEMP HEAD DRV**, the temperature of the LED driver board

**TEMP HEAD LED**, the temperature of the LED module

**TEMP HEAD AMBIENT**, the temperature in the head next to the air inlet (ambient temperature)

Both the current temperature and the maximum temperature are displayed. The maximum temperatures can be individually deleted.

## **6.8 Shortcuts - quick access**

### ESC + DOWN

Pressing the ESC and DOWN buttons in the main menu will log the fixture off the programmed Lumen Radio Wireless transmitter. The fixture is now ready to be logged in another transmitter.

### ENTER + UP

If ENTER + UP is pressed in the main screen, the screen orientation is rotated by 180 °.

### ENTER + ESC

By pressing the ENTER and ESC key, the fixture is locked for user input -> LOCKED. ESC and ENTER release the lock again!

## 7. Control options

### 7.1 DMX

#### 7.1.1 Operating modes P15 Wash

The P15 Wash has 2 different DMX modes. The respective mode can be set in the PERSONALITY, DMX MODE menu item. The set mode is displayed in the main menu.

|            | <b>Mode 1(M1)</b>            | <b>Mode 2 (M2)</b>          |
|------------|------------------------------|-----------------------------|
| Channel 1  | Pan                          | Pan                         |
| Channel 2  | Pan fine                     | Pan fine                    |
| Channel 3  | Tilt                         | Tilt                        |
| Channel 4  | Tilt fine                    | Tilt fine                   |
| Channel 5  | Control channel              | Control channel             |
| Channel 6  | Shutter                      | Shutter                     |
| Channel 7  | Dimmer                       | Dimmer                      |
| Channel 8  | Focus                        | Fine dimmer                 |
| Channel 9  | Zoom                         | Focus                       |
| Channel 10 | Reserved                     | Fine focus                  |
| Channel 11 | Iris                         | Zoom                        |
| Channel 12 | Aperture 1a / 1 Thrust       | Fine zoom                   |
| Channel 13 | Aperture 1b / 1 Angle        | Reserved                    |
| Channel 14 | Aperture 2a / 2 Thrust       | Iris                        |
| Channel 15 | Aperture 2b / 2 Angle        | Fine iris                   |
| Channel 16 | Aperture 3a / 3 Thrust       | Aperture 1a / 1 Thrust      |
| Channel 17 | Aperture 3b / 3 Angle        | Aperture 1a / 1 Thrust fine |
| Channel 18 | Aperture 4a / 4 Thrust       | Aperture 1b / 1 Angle       |
| Channel 19 | Aperture 4b / 4 Angle        | Aperture 1b / 1 Angle fine  |
| Channel 20 | Aperture rotation            | Aperture 2a / 1 Thrust      |
| Channel 21 | Colour wheel                 | Aperture 2a / 1 Thrust fine |
| Channel 22 | Cyan                         | Aperture 2b / 1 Angle       |
| Channel 23 | Magenta                      | Aperture 2b / 1 Angle fine  |
| Channel 24 | Yellow                       | Aperture 3a / 1 Thrust      |
| Channel 25 | Color fulness                | Aperture 3a / 1 Thrust fine |
| Channel 26 | CTO                          | Aperture 3b / 1 Angle       |
| Channel 27 | CTC                          | Aperture 3b / 1 Angle fine  |
| Channel 28 | Black Body Shift (+/- Green) | Aperture 4a / 1 Thrust      |
| Channel 29 | Sparkle                      | Aperture 4a / 1 Thrust fine |
| Channel 30 | Sparkle speed                | Aperture 4b / 1 Angle       |
| Channel 31 | Frost                        | Aperture 4b / 1 Angle fine  |
| Channel 32 | Reserved                     | Aperture rotation           |
| Channel 33 | Pan/tilt speed               | Fine aperture rotation      |
| Channel 34 | Effect speed                 | Colour wheel                |
| Channel 35 | Blackout Move                | Cyan                        |
| Channel 36 |                              | Fine cyan                   |
| Channel 37 |                              | Magenta                     |
| Channel 38 |                              | Fine magenta                |
| Channel 39 |                              | Yellow                      |
| Channel 40 |                              | Fine yellow                 |

# P 15 WASH

---

|            |                              |
|------------|------------------------------|
| Channel 41 | Color fulness                |
| Channel 42 | Color fulness fine           |
| Channel 43 | CTO                          |
| Channel 44 | CTO fine                     |
| Channel 45 | CTC                          |
| Channel 46 | Black body Shift (+/- Green) |
| Channel 47 | Sparkle                      |
| Channel 48 | Sparkle speed                |
| Channel 49 | Frost                        |
| Channel 50 | Reserved                     |
| Channel 51 | Blackout Move                |

## 7.1.2 DMX channel functions P15 Wash

| M1 | M2 | M3 | Function   | DMX   |
|----|----|----|--|---|
| 1  | 1  |    | <b>Pan (X)</b> movement 546,74°  | 000-255   |
| 2  | 2  |    | <b>Pan (X)</b> fine (16 Bit)   | 000-255   |
| 3  | 3  |    | <b>Tilt (Y)</b> movement 281,16°   | 000-255   |
| 4  | 4  |    | <b>Tilt (Y)</b> fine (16 Bit)  | 000-255   |
| 5  | 5  |    | <p><b>Control channel - Attention: The control channel functions are not locked by default. Note the PERSONALITY -&gt; SAVE MODE SWITCH setting!</b><br/>           To enable uniform dimming manually via faders for all light mixing consoles, 5 different settings for the DMX smoothing are available. If the DMX signal is interrupted or too few packets are sent on some DMX consoles, the response of the Sparx 18/30 can be adjusted with this channel. The Minimum DMX Smoothing setting should work on most popular consoles. The values for DMX smoothing must be permanent. For the other values, such as cooling mode, color temperature, zoom modes, camera mode, reset, the values must be applied for 2 seconds, then the device will be permanently switched (Same setting as in the PERSONALITY menu).</p> <p><b>Setting for minimal DMX smoothing</b><br/>           (A dimmed shutter sequence is possible)<br/>           Dimmer fade out via fader (fast - slow)<br/>           not used</p> <p><b>Setting for minimum / medium DMX smoothing</b><br/>           Dimmer fade out via fader (fast - slow)<br/>           not used</p> <p><b>Setting for medium DMX smoothing</b><br/>           Dimmer fade out via fader (fast - slow)<br/>           not used</p> <p><b>Setting for medium / maximum DMX smoothing</b><br/>           Dimmer fade out via fader (fast - slow)</p> <p><b>BACKLIGHT MODE - Display backlight configuration</b><br/>           OFF - the backlight is always off until a key is pressed<br/>           ON - the backlight is always on<br/>           AUTO - the fixture controls the backlight automatically</p> <p><b>DISPLAY ORIENTATION - display flip or not</b><br/>           STANDARD - the display can be read when the headlamp is on a surface<br/>           FLIP - the display orientation is rotated by 180 °, hanging readable<br/>           not used</p> <p><b>MAIN SCREEN MODE - view of the main screen</b><br/>           STANDARD - the main screen displays the DMX address, the DMX mode, and when wireless is enabled, the field strength.<br/>           USER FIXTURE ID - the main screen displays the user definable fixture ID / headlight number<br/>           not used</p> <p><b>USER FIXTURE ID SET - Scheinwerfernummer setzen</b><br/>           SET - the USER ID can be set. The headlamp takes the 16-bit value of Pan for the USER ID<br/>           not used</p> | <p>000-007<br/>008-031</p> <p>032-039<br/>040-063</p> <p>064-071<br/>072-095</p> <p>096-103</p> <p>104-104<br/>105-105<br/>106-106</p> <p>107-107<br/>108-108<br/>109-109</p> <p>110-110<br/>111-111<br/>112-112</p> <p>113-113<br/>114-115</p> |

|  |   |   |
|--|---|---|
|  | <p><b>BLACK BODY SHIFT - set of green shift</b><br/>         BLACK BODY SHIFT - The headlamp takes the 16-bit value of Pan for the BLACK BODY SHIFT. Values from -99 to +99 (DMX values 0 to 65535, 32768 is no shift)<br/>         not used</p>  | <p>116-116<br/>         117-127</p>   |
|  | <p><b>Setting for maximum DMX smoothing</b><br/>         Dimmer fade out via fader (fast - slow)</p>  | <p>128-135</p>  |
|  | <p><b>DIMMER CURVE - selection of dimmer curve</b><br/>         LINEAR - linear dimmer curve<br/>         SQUARE - exponential dimmer curve<br/>         SQUARE INVERSE - exponential inverse dimmer curve<br/>         not used</p>  | <p>136-136<br/>         137-137<br/>         138-138<br/>         139-139</p>   |
|  | <p><b>RGB/CMY CURVE - selection of RGB/CMY curve</b><br/>         LINEAR - linear RGB/CMY<br/>         SQUARE INVERSE - Exponential inverse RGB/CMY curve<br/>         SQUARE - Exponential RGB/CMY curve</p>   | <p>140-140<br/>         141-141<br/>         142-142</p>  |
|  | <p><b>FROST CURVE - selection of frost curve</b><br/>         LINEAR - linear frost curve<br/>         SQUARE INVERSE - Exponential inverse frost curve<br/>         not used</p>   | <p>143-143<br/>         144-144<br/>         145-145</p>  |
|  | <p><b>PAN/TILT SPEED - selection of PAN/TILT speed</b><br/>         WHISPER<br/>         MEDIUM<br/>         FOLLOW<br/>         FAST</p>   | <p>146-146<br/>         147-147<br/>         148-148<br/>         149-149</p>   |
|  | <p><b>EFFECT SPEED - selection of effect speed</b><br/>         WHISPER<br/>         SILENT<br/>         MEDIUM<br/>         FAST</p>   | <p>150-150<br/>         151-151<br/>         152-152<br/>         153-153</p>   |
|  | <p><b>LED FADE OUT MODE - selection of dimming out</b><br/>         STANDARD<br/>         SOFT</p>  | <p>154-154<br/>         155-155</p>   |
|  | <p><b>BLMODE - type of shutter control</b><br/>         RAW<br/>         MOVE/ANGLE</p>   | <p>156-156<br/>         157-157</p>   |
|  | <p><b>BLROT DIR - switching the direction of the shutter rotation</b><br/>         NORMAL<br/>         INVERS</p>   | <p>158-158<br/>         159-159</p>   |
|  | <p><b>COOLING MODE - Adjust the fan volume and brightness</b><br/>         This takes place with dimmer / shutter set to closed (DMX 000) then after 2 seconds the fixture will switch this option, except the switch "SAFE MODE SWITCH" in the PERSONALITY menu is set to OFF, then the changeover can take place directly without dimmer and shutter having to be closed.<br/>         THEATRE WHISPER<br/>         THEATRE SILENT<br/>         STANDARD<br/>         BOOST<br/>         LONGLIFE<br/>         not used</p> | <p>160-160<br/>         161-161<br/>         162-162<br/>         163-163<br/>         164-164<br/>         165-184</p> |

|    |    |  |   |
|----|----|--|---|
|    |    | <b>COLOR MIX MODE - selection of color mixing mode RGBW or CMY</b><br>RGBW<br>CMY (default)<br>not used  | 185-185<br>186-186<br>187-207   |
|    |    | <b>CAMERA MODE - Setting the LED refresh rate</b><br>50Hz<br>60Hz<br>FLEX - 600Hz<br>High FLEX - 3kHz - 18kHz<br>not used  | 208-215<br>216-223<br>224-227<br>228-231<br>232-239   |
|    |    | <b>RESET - a basic reset of the fixture is carried out</b><br>Reset (after 2 seconds)<br>nicht belegt  | 240-247<br>248-255  |
| 6  | 6  | <b>Shutter</b><br>Shutter closed<br>Shutter open<br>Open pulsing shutter >20Hz (rapid - slow)<br>Shutter open<br>Fade effect with dimmer (slow - rapid)<br>Shutter open<br>Shutter closed<br>Open pulsing shutter <20Hz (rapid - slow)<br>Shutter open<br>Close pulsing shutter >20Hz (rapid - slow)<br>Shutter closed<br>Shutter fade, 0% (rapid - slow)<br>Shutter open<br>Shutter fade, 100% (rapid - slow)<br>Shutter closed<br>Random shutter 100% (rapid - slow)<br>Shutter open<br>Random shutter 0% (rapid - slow)<br>Shutter closed<br>Random shutter fade, 0% (rapid- slow)<br>Shutter open<br>Random shutter fade, 100% (rapid- slow)<br>Shutter open | 000-015<br>016-095<br>096-110<br>111-111<br>112-125<br>126-126<br>127-127<br>128-142<br>143-143<br>144-158<br>159-159<br>160-174<br>175-175<br>176-190<br>191-191<br>192-206<br>207-207<br>208-222<br>223-223<br>224-238<br>239-239<br>240-254<br>255-255 |
| 7  | 7  | <b>Dimmer 0 - 100%</b>   | 000-255   |
|    | 8  | <b>Dimmer fine (16Bit)</b>   | 000-255   |
| 8  | 9  | <b>Focus 0-100%</b>  | 000-255   |
|    | 10 | <b>Focus fine (16 Bit)</b>   | 000-255   |
| 9  | 11 | <b>Zoom 0 -100% (near 9° - far 66°)</b>  | 000-255   |
|    | 12 | <b>Zoom fine (16 Bit)</b>  | 000-255   |
| 10 | 13 | <b>Reserved</b>  | 000-255   |

# P 15 WASH

|    |    |  |  |   |
|----|----|--|--|---|
| 11 | 14 |  | <b>Iris 0-100%</b> (open -> closed)  | 000-255   |
|    | 15 |  | <b>Iris fine</b> (16Bit)   | 000-255   |
| 12 | 16 |  | <b>Aperture 1a / 1 Thrust 0-100%</b>   | 000-255   |
|    | 17 |  | <b>Aperture 1a / 1 Thrust fine</b> (16 Bit)  | 000-255   |
| 13 | 18 |  | <b>Aperture 1b / 1 Angle 0-100%</b>  | 000-255   |
|    | 19 |  | <b>Aperture 1b / 1 Angle fine</b> (16 Bit)   | 000-255   |
| 14 | 20 |  | <b>Aperture 2a / 2 Thrust 0-100%</b>   | 000-255   |
|    | 21 |  | <b>Aperture 2a / 2 Thrust fine</b> (16 Bit)  | 000-255   |
| 15 | 22 |  | <b>Aperture 2b / 2 Angle 0-100%</b>  | 000-255   |
|    | 23 |  | <b>Aperture 2b / 2 Angle fine</b> (16 Bit)   | 000-255   |
| 16 | 24 |  | <b>Aperture 3a / 3 Thrust 0-100%</b>   | 000-255   |
|    | 25 |  | <b>Aperture 3a / 3 Thrust fine</b> (16 Bit)  | 000-255   |
| 17 | 26 |  | <b>Aperture 3b / 3 Angle 0-100%</b>  | 000-255   |
|    | 27 |  | <b>Aperture 3b / 3 Angle fine</b> (16 Bit)   | 000-255   |
| 18 | 28 |  | <b>Aperture 4a / 4 Thrust 0-100%</b>   | 000-255   |
|    | 29 |  | <b>Aperture 4a / 4 Thrust fine</b> (16 Bit)  | 000-255   |
| 19 | 30 |  | <b>Aperture 4b / 4 Angle 0-100%</b>  | 000-255   |
|    | 31 |  | <b>Aperture 4b / 4 Angle fine</b> (16 Bit)   | 000-255   |
| 20 | 32 |  | <b>Aperture rotation -65° / +65°</b>   | 000-255   |
|    | 33 |  | <b>Aperture rotation fine</b> (16 Bit)   | 000-255   |
| 21 | 34 |  | <b>Color wheel</b><br>White<br>White/Red<br>Red<br>Red/Yellow<br>Yellow<br>Yellow/Magenta<br>Magenta<br>Magenta/Green<br>Green<br>Green/Orange<br>Orange<br>Orange/Dark Blue<br>Dark Blue<br>Dark Blue/ HCRI<br>HCRI | 000-001<br>002-003<br>004-005<br>006-007<br>008-009<br>010-011<br>012-013<br>014-015<br>016-017<br>018-019<br>020-021<br>022-023<br>024-025<br>026-027<br>028-029 |

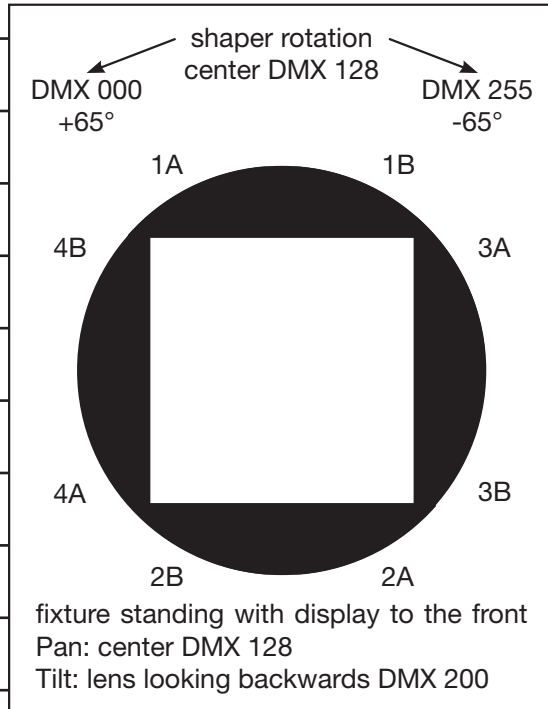



# P15 WASH

|    |    |  |  |
|----|----|--|--|
| 33 |    | <b>Pan/tilt speed</b><br>Real-time motion<br>Delayed motion (rapid - slow)   | 000-003<br>004-255   |
| 34 |    | <b>Effects speed</b><br>Real-time effects<br>Delayed effects (rapid - slow)  | 000-003<br>004-255   |
| 35 | 51 | <b>Blackout Move</b><br>Not assigned<br>Blackout during pan/tilt<br>Blackout during Gobo, Colour, Prism, CMY, Iris, Frost<br>Blackout during Gobo, Colour, Prism, CMY, Iris, Frost, Zoom, Focus<br>Blackout during Gobo, Colour, Prism, CMY, Iris, Frost, Pan/Tilt<br>Blackout during Gobo, Colour, Prism, CMY, Iris, Frost, Zoom, Focus, Pan/Tilt | 000-095<br>096-127<br>128-159<br>160-191<br>192-223<br>224-255 |

## 7.1.3 Control channel

**Caution: The control channel functions are not locked by default. Note the PERSONALITY -> SAVE MODE SWITCH setting!**

Via the control channel different functions of the fixture can be switched. The following functions can be switched via the control channel.

Response of the headlamp when dimming via faders

BACKLIGHT MODE - display backlight

DISPLAY ORIENTATION - display orientation

MAIN SCREEN MODE - main screen view

USER FIXTURE ID SET - set headlight number

DIMMER CURVE - dimmer curve adjustment

FROST CURVE - setting the frost curve

PAN / TILT SPEED - pan / tilt speed

EFFECT SPEED - effect speed

LED FADE OUT MODE - type of dimming

BL MODE - type of shutter control (only P15 Wash)

BL ROT DIR - direction of blade module rotation (only P15 Wash)

COLOR MIX MODE - Setting the control of the color mixture RGB or CMY

COOLING MODE - adjust the fan volume and brightness

CAMERA MODE - sets the LED refresh rate

RESET - a basic reset of the headlight is performed

For details, see DMX Channel Functions for the P15 Wash on page 25.

## 7.1.4 Sparkle effect, sparkle speed

Animation effects can be created via this channel in connection with the focus. Depending on the intensity, the projection can be made to shake more or less. This effect can be dimmed or switched.

## **7.2 Artnet**

The spotlight can be controlled via Artnet - ArtNET 4. To do this, set the Artnet address via the menu item DMX / NET ADDR -> ARTNET ADDRESS and also select it via the menu item PERSONALITY -> DMX INPUT CONFIG -> NETWORK -> MODE -> ARTNET. In addition, define the IP address of the spotlight via PERSONALITY -> DMX INPUT CONFIG -> NETWORK -> IP ADDRESS. Further details and setting options can be found on page 17

## **7.3 Streaming ACN**

The headlight can be controlled via sACN - Streaming ACN. To do this, set the sACN address via the menu item DMX / NET ADDR -> SACN ADDRESS and also select it via the menu item PERSONALITY -> DMX INPUT CONFIG -> NETWORK -> MODE -> SACN. In addition, define the IP address of the spotlight via PERSONALITY -> DMX INPUT CONFIG -> NETWORK -> IP ADDRESS. Further details and setting options can be found on page 17

## **7.4 Wireless-DMX**

The P15 is equipped with a Lumen Radio GRMX receiver for wireless DMX. The receiver can process both DMX and RDM. If there is a cable and wireless connection to the P15, the cable connection has priority! The received signal can be output via the DMX connection. To do this, set the DMX OUTPUT CONFIG setting to ON in the PERSONALITY menu. After confirming with ENTER, the spotlight will output the entire universe received via wireless DMX.

## **7.5 RDM**

The P15 can communicate via RDM (Remote Device Management) in accordance with ESTA American National Standard E1.20-2006. RDM is a bidirectional communication protocol for use in DMX512 control systems. It is the open standard for the configuration and status monitoring of DMX-512 devices. The RDM protocol enables data packets to be inserted into a DMX-512 data stream without affecting existing non-RDM devices. It enables a console or dedicated RDM controller to send commands to specific devices and receive messages. The P18 can send and receive RDM via DMX and Artnet 4. The spotlight is also designed to send RDM via sACN and receive it via Artnet. The RDM functionality depends on the lighting control desk used, the operating instructions of the respective desk manufacturer must also be observed.

### **7.5.1 RDM-UID**

Every P15 has a factory-set RDM-UID (unique identification number), which makes it addressable and identifiable in RDM systems.

### **7.5.2 RDM-PIDs**

The P15 supports the RDM PIDs (parameter IDs) required by ESTA as well as manufacturer-specific PIDs.

## 7.5.3 Standard RDM parameter IDs

| RDM parameter ID            | GET | SET | DISCO-<br>VERY | Note                               |
|-----------------------------|-----|-----|----------------|------------------------------------|
| RDM identification          |     |     |                |                                    |
| DISC_UNIQUE_BRANCH          |     |     | ✓              | is used for fixture identification |
| DISC_MUTE                   |     |     | ✓              | is used for fixture identification |
| DISC_UN_MUTE                |     |     | ✓              | is used for fixture identification |
| RDM status determination    |     |     |                |                                    |
| QUEUED_MESSAGE              | ✓   |     |                |                                    |
| STATUS_MESSAGES             | ✓   |     |                |                                    |
| STATUS_ID_DESCRIPTION       | ✓   |     |                |                                    |
| CLEAR_STATUS_ID             |     | ✓   |                |                                    |
| RDM information             |     |     |                |                                    |
| SUPPORTED_PARAMETERS        | ✓   |     |                |                                    |
| RDM configuration           |     |     |                |                                    |
| DEVICE_MODEL_DESCRIPTION    | ✓   |     |                |                                    |
| MANUFACTURER_LABEL          | ✓   |     |                |                                    |
| FACTORY_DEFAULTS            |     | ✓   |                |                                    |
| SOFTWARE_VERSION_LABEL      | ✓   |     |                |                                    |
| DMX_PERSONALITY             |     | ✓   |                |                                    |
| DMX_PERSONALITY_DESCRIPTION | ✓   |     |                |                                    |
| DMX_START_ADDRESS           |     | ✓   |                |                                    |
| SENSOR_DEFINITION           | ✓   |     |                |                                    |
| DEVICE_HOURS                | ✓   |     |                |                                    |
| LAMP_HOURS                  | ✓   |     |                |                                    |
| IDENTIFY_DEVICE             |     | ✓   |                |                                    |
| RESET_DEVICE                |     | ✓   |                |                                    |
| PERFORM_SELFTEST            |     | ✓   |                |                                    |
| SELFTEST_DESCRIPTION        | ✓   |     |                |                                    |

## 7.5.4 Manufacturer specific RDM parameter IDs

| RDM parameter ID      | GET | SET | DISCO-<br>VERY | Note |
|-----------------------|-----|-----|----------------|------|
| RDM configuration     |     |     |                |      |
| Battery Charge Hours  | ✓   |     |                |      |
| Error Number          | ✓   |     |                |      |
| Error                 | ✓   |     |                |      |
| Select Next Error     |     | ✓   |                |      |
| Remove Error          |     | ✓   |                |      |
| Remove New Error Flag |     | ✓   |                |      |
| User Defaults         |     | ✓   |                |      |
| User Fixture ID       |     | ✓   |                |      |
| Fixture Lock On/Off   | ✓   | ✓   |                |      |
| Dimmer Curve          | ✓   | ✓   |                |      |
| RGB Curve             | ✓   | ✓   |                |      |
| Frost Curve           | ✓   | ✓   |                |      |
| Camera Mode           | ✓   | ✓   |                |      |
| Cooling Mode          | ✓   | ✓   |                |      |

|                   |   |   |  |  |
|-------------------|---|---|--|--|
| Pan Tilt Speed    | ✓ | ✓ |  |  |
| Effect Speed      | ✓ | ✓ |  |  |
| Backlight Mode    | ✓ | ✓ |  |  |
| Disp Orientation  | ✓ | ✓ |  |  |
| Main Screen Mode  | ✓ | ✓ |  |  |
| Safe Mode Switch  | ✓ | ✓ |  |  |
| LED Fade Out Mode | ✓ | ✓ |  |  |
| Blade Rot Dir     | ✓ | ✓ |  |  |
| Blade Mode        | ✓ | ✓ |  |  |
| Color Mix Mode    | ✓ | ✓ |  |  |

## 7.5.5 RDM sensor IDs

| RDM sensor ID      | GET | SET | DISCO-<br>VERY | Note |
|--------------------|-----|-----|----------------|------|
| RDM sensors        |     |     |                |      |
| Temp Sens Base LCD | ✓   | ✓   |                |      |
| Temp Sens Base PS  | ✓   | ✓   |                |      |
| Temp Sens Head PCB | ✓   | ✓   |                |      |
| Temp Sens Head Drv | ✓   | ✓   |                |      |
| Temp Sens Head LED | ✓   | ✓   |                |      |
| Temp Sens Head Air | ✓   | ✓   |                |      |

## 8. Service

### 8.1 Service menu

#### RESET FIXTURE

Upon the “Reset” command, P15 will initialise to its initial values. It is the same procedure as after switching on the P15. If an error message appears in the display, this could be the first step to correct it.

#### ERROR LIST

The P15 stores all occurring errors internally. An error message can have a harmless cause. If you experience frequent error messages, please contact your dealer or the JB-Lighting service department. All error messages are displayed with the respective frequency and can be deleted.

#### FUNCTION TEST

This function allows you to test all functions of the P15 without using a light mixer. The pan/tilt reset is deactivated in the process.

#### DMX TEST

This menu item is used to test the DMX input. Use the function keys to select the DMX channel to be tested. The display shows the incoming value, at the same time the P15 reacts accordingly.

#### INIT PAN TILT

The P15 is calibrated in the pan/tilt position at the factory. If it loses this calibration, i.e. it strikes against the stop or no longer finds its position, it can be re-initialised using this function. This process takes about 3-4 minutes and ends with a reset of the spotlight.

#### FINE ADJUST

The FINE ADJUST area is protected by a key combination. Focus, shapers, shaper rotation, pan and tilt are calibrated at the factory. If there are large deviations in the calibration between the individual headlights, this can be corrected in the FINE ADJUST menu. For more information please contact our service.

## IDENTIFY DEVICE

The RDM command IDENTIFY DEVICE can be called up or deactivated via this menu item.

## 8.2 Software update

The P15 can be updated via a USB stick with micro-USB connection. To do this, copy the file directly into the root directory of the USB stick. Then press and hold the right key below the display, switch on the power of the P15 as soon as the message “Insert USB stick” appears on the display release the key. Now plug in the USB stick on the back of the device below the signal connections and follow the instructions on the display. The P15 completes the software update with a reset. You will find the latest software on our homepage.

## 8.3 Testing of electrical equipment

According to the German Social Accident Insurance (DGUV) Regulation 3 / Regulation 4, electrical systems and equipment must be subjected to regular inspections. The fixing screw of the DMX 5-pin socket can be used as measuring point for insulation and residual current measurement. The screw is connected to all sheet metal parts via a contact washer.



## 8.4 Optional pan/tilt limitation

The P15 Wash offers the option of installing a pan/tilt limitation. The following parts are included with the limitation:

2x Tilt stop with fastening screw



2x Pan stop with fastening screw



### 8.4.1 Installation of the limitation

The pictures show the installation of the pan/tilt limiter on the M18. The installation on the P15 is nearly the same.

For installation, tweezers or needle-nose pliers, a Torx TX10 and a Torx TX20 are required.

In order to install the pan/tilt limitation, the two arm side parts must first be removed. To do this, 6 screws each must be loosened in order to be able to remove the side panel. See image.



In the next step, the rotating parts for the tilt limitation are installed. To do this, use tweezers/nose-nosed pliers to insert the rotating part between the head and the arm, place it in the corresponding hole from behind and tighten the screw with the Torx TX20 screwdriver. Repeat this procedure accordingly for the 2nd stop. For example to get a limited movement from  $-66^\circ$  to  $66^\circ$  you have to put the stops in hole **6** for the first stop and hole **23** for the second stop.

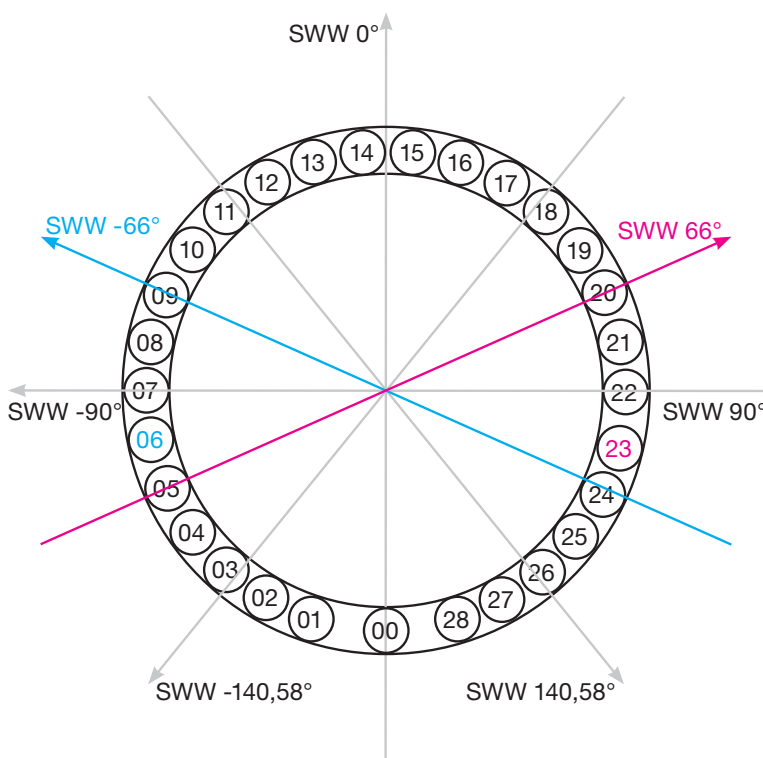

| Pos       | AN1        | SWW         | Pos       | AN2         | SWW        |
|-----------|------------|-------------|-----------|-------------|------------|
| 00        | 0°         | -140,58°    | 00        | 360°        | 140,58     |
| 01        | 18°        | -126°       | 28        | 342°        | 126°       |
| 02        | 30°        | -114°       | 27        | 330°        | 114°       |
| 03        | 42°        | -102°       | 26        | 318°        | 102°       |
| 04        | 54°        | -90°        | 25        | 306°        | 90°        |
| 05        | 66°        | -78°        | 24        | 294°        | 78°        |
| <b>06</b> | <b>78°</b> | <b>-66°</b> | <b>23</b> | <b>282°</b> | <b>66°</b> |
| 07        | 90°        | -54°        | 22        | 270°        | 54°        |
| 08        | 102°       | -42°        | 21        | 258°        | 42°        |
| 09        | 114°       | -30°        | 20        | 246°        | 30°        |
| 10        | 126°       | -18°        | 19        | 234°        | 18°        |
| 11        | 138°       | -6°         | 18        | 222°        | -6°        |
| 12        | 150°       | 6°          | 17        | 210°        | 6°         |
| 13        | 162°       | 18°         | 16        | 198°        | 18°        |
| 14        | 174°       | 30°         | 15        | 186°        | 30°        |
| 15        | 186°       | 42°         | 14        | 174°        | 42°        |
| 16        | 198°       | 54°         | 13        | 162°        | 54°        |
| 17        | 210°       | 66°         | 12        | 150°        | 66°        |

SWW -> max tilt angle of the fixture  
AN -> stop

# P 15 WASH

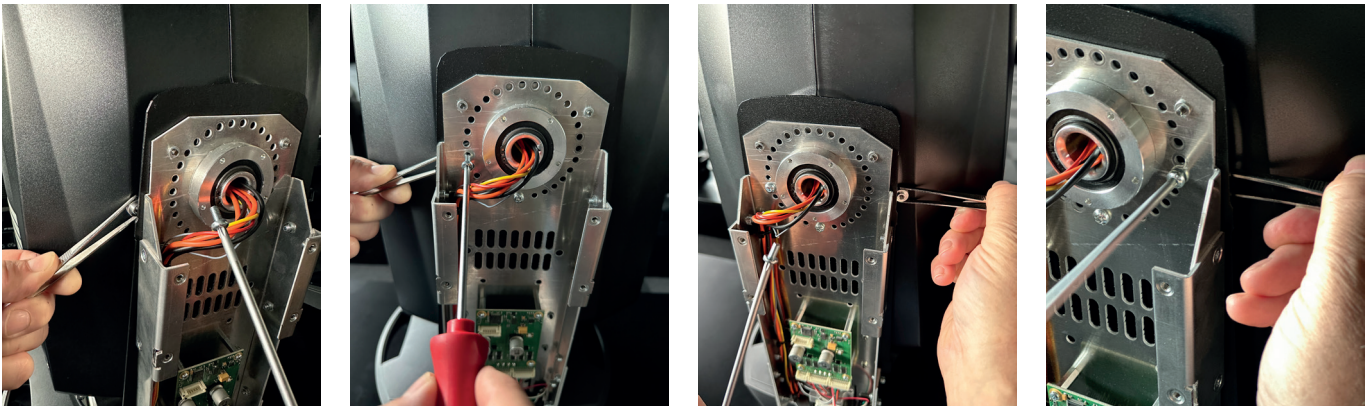

This results in a tilt path as shown in the two images on the right, as in the example from  $-66^{\circ}$  to  $66^{\circ}$

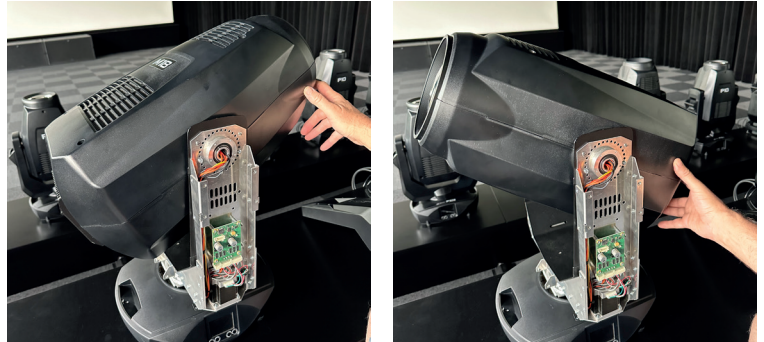

Now the parts for the PAN limitation are installed. To do this, place the perforated bricks on the intended screw holes according to the desired angle and fix them with the two TX10 screws (see pictures). An overview about the angles you will see at the following page.

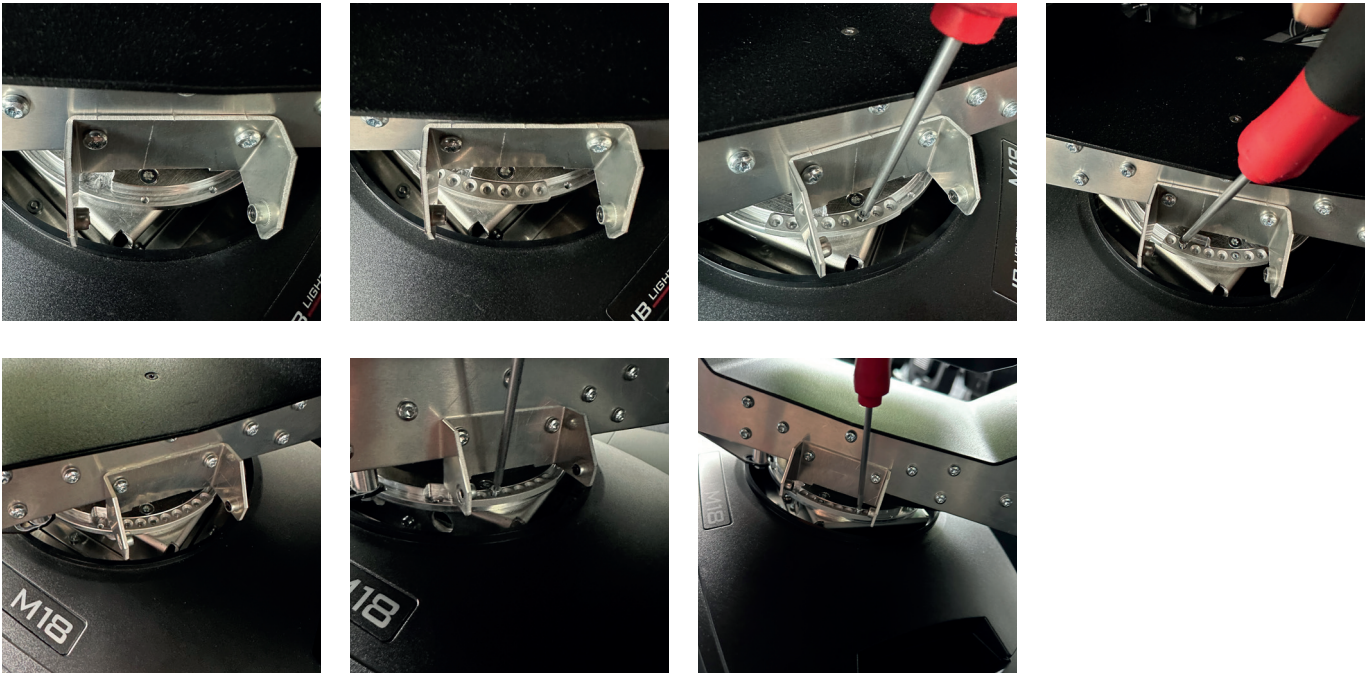

This results in a pan path as shown in the two images on the right, as in the example.



| SWW   | Pos. | AN1    |
|-------|------|--------|
| -288  | 00   | 1 00°  |
| -282  |      | 2 06°  |
| -276  |      | 3 12°  |
| -270  |      | 4 18°  |
| -264  | 01   | 1 24°  |
| -258  |      | 2 30°  |
| -252  |      | 3 36°  |
| -246  |      | 4 42°  |
| -240  | 02   | 1 48°  |
| -234  |      | 2 54°  |
| -228  |      | 3 60°  |
| -222  |      | 4 66°  |
| -216  | 03   | 1 72°  |
| -210  |      | 2 78°  |
| -204  |      | 3 84°  |
| -198  |      | 4 90°  |
| -192  | 04   | 1 96°  |
| -186  |      | 2 102° |
| -180° |      | 3 108° |
| -174° |      | 4 114° |
| -168° | 05   | 1 120° |
| -162° |      | 2 126° |
| -156° |      | 3 132° |
| -150° |      | 4 138° |
| -144° | 06   | 1 144° |
| -138° |      | 2 150° |
| -132° |      | 3 156° |
| -126° |      | 4 162° |
| -120° | 07   | 1 168° |
| -114° |      | 2 174° |
| -108° |      | 3 180° |
| -102° |      | 4 186° |
| -96°  | 08   | 1 192° |
| -90°  |      | 2 198° |
| -84°  |      | 3 204° |
| -78°  |      | 4 210° |
| -72°  | 09   | 1 216° |
| -66°  |      | 2 222° |
| -60°  |      | 3 228° |
| -54°  |      | 4 234° |
| -48°  | 10   | 1 240° |
| -42°  |      | 2 246° |
| -36°  |      | 3 252° |
| -30°  |      | 4 258° |
| -24°  | 11   | 1 264° |
| -18°  |      | 2 270° |
| -12°  |      | 3 276° |
| -6°   |      | 4 282° |
| 0°    | 12   | 1 288° |
| 6°    |      | 2 294° |
| 12°   |      | 3 300° |
| 18°   |      | 4 306° |
| 24°   | 13   | 1 312° |
| 30°   |      | 2 318° |
| 36°   |      | 3 324° |
| 42°   |      | 4 330° |
| 48°   | 14   | 1 336° |
| 54°   |      | 2 342° |
| 60°   |      | 3 348° |
| 66°   |      | 4 354° |
| 72°   | 00   | 360°   |

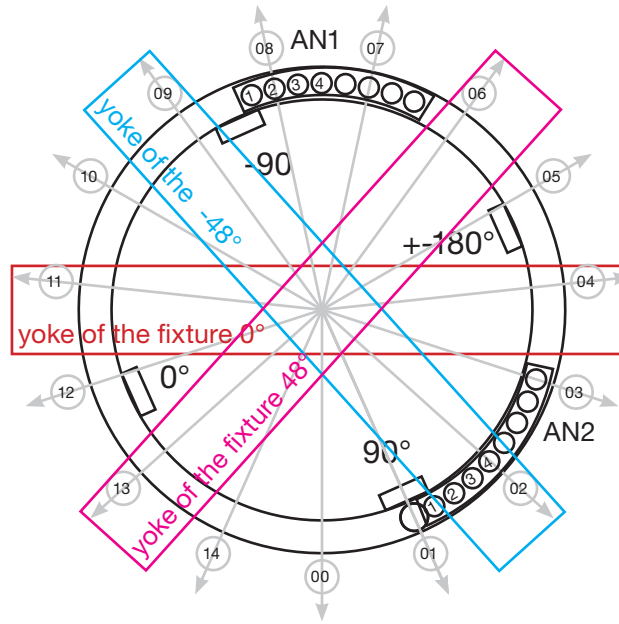

display of the fixture

| SWW   | Pos. | AN2    |
|-------|------|--------|
| -108° |      | 1 -12° |
| -102° | 09   | 4 -18° |
| -96°  |      | 3 -24° |
| -90°  |      | 2 -30° |
| -84°  |      | 1 -36° |
| -78°  | 10   | 4 -42° |
| -72°  |      | 3 -48° |
| -66°  |      | 2 -54° |
| -60°  |      | 1 -60° |
| -54°  | 11   | 4 -66° |
| -48°  |      | 3 -72° |
| -42°  |      | 2 -78° |
| -36°  |      | 1 -84° |
| -30°  | 12   | 4 -90° |
| -24°  |      | 3 -84° |
| -18°  |      | 2 -78° |
| -12°  |      | 1 -72° |
| -6°   | 13   | 4 -66° |
| 0°    |      | 3 -60° |
| 6°    |      | 2 -54° |
| 12°   |      | 1 -48° |
| 18°   | 14   | 4 -42° |
| 24°   |      | 3 -36° |
| 30°   |      | 2 -30° |
| 36°   |      | 1 -24° |
| 42°   | 00   | 4 -18° |
| 48°   |      | 3 -12° |
| 54°   |      | 2 -06° |
| 60°   |      | 1 00°  |
| 66°   | 01   | 4 06°  |
| 72°   |      | 3 12°  |
| 78°   |      | 2 18°  |
| 84°   |      | 1 24°  |
| 90°   | 02   | 4 30°  |
| 96°   |      | 3 36°  |
| 102°  |      | 2 42°  |
| 108°  |      | 1 48°  |
| 114°  | 03   | 4 54°  |
| 120°  |      | 3 60°  |
| 126°  |      | 2 66°  |
| 132°  |      | 1 72°  |
| 138°  | 04   | 4 78°  |
| 144°  |      | 3 84°  |
| 150°  |      | 2 90°  |
| 156°  |      | 1 96°  |
| 162°  | 05   | 4 102° |
| 168°  |      | 3 108° |
| 174°  |      | 2 114° |
| 180°  |      | 1 120° |
| 186°  | 06   | 4 126° |
| 192°  |      | 3 132° |
| 198°  |      | 2 138° |
| 204°  |      | 1 144° |
| 210°  | 07   | 4 150° |
| 216°  |      | 3 156° |
| 222°  |      | 2 162° |
| 228°  |      | 1 168° |
| 234   | 08   | 4 174° |
| 240   |      | 3 180° |
| 246   |      | 2 186° |
| 252   |      | 1 192° |

SWW -> max tilt angle of the fixture  
AN -> stop

# P 15 WASH

Now the fixture has to be taught that it has new end points for Pan/Tilt. To do this, press and hold buttons 1 and 3 below the display and plug in the fixture. As soon as the main menu appears, the buttons can be released. Press the ENTER key as often till the SET PAN/TILT TYPE selection appears. To activate the pan/tilt limit, press the 2nd button from the left (LIMIT). The spotlight now carries out an INIT PAN/TILT and thus finds its 2 limits and saves them. This init is completed by a reset. Finally, all that remains is to reinstall the two arm covers and the fixture is now ready for limited pan/tilt movement!



## 8.4.2 Removal/dismantling of the limitation

In order to remove the travel limitation again, the two arm side parts must be removed. To do this, 6 screws each must be loosened in order to be able to remove the side panel. Then remove all the built-in additional parts and switch the headlight back to "without" limitation. To do this, press and hold buttons 1 and 3 below the display and plug in the headlight. As soon as the main menu appears, the buttons can be released. Press the ENTER key as often till the SET PAN/TILT TYPE selection appears. To deactivate the pan/tilt limitation, press the 1st button from the left (MAX). The spotlight now performs an INIT PAN/TILT and finds its stop (Hall sensor) again and saves this value. This init is completed by a reset. Finally, only the two arm covers have to be reinstalled and the headlight is now ready for a "full" pan/tilt ride.

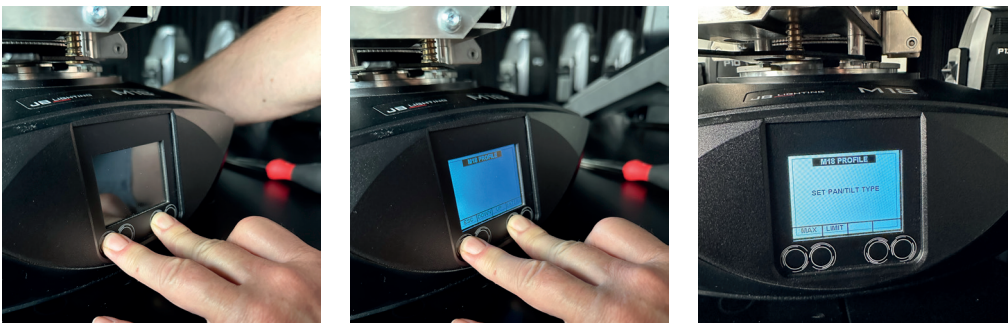

## 8.5 Cleaning the device



**ATTENTION:** Allow the device to cool down and disconnect the device from the mains before opening the device. Touching live parts (high voltage) can give you an electric shock.

You should check the function of the fans in the head and foot at regular intervals. Above all, you should make sure that the air inlets and the inside of the P15 are free of fluff and dust. Also make sure that the dust filters in the covers are clean. Open the head cover (4x camlocks with a half turn) and the bottom plate on the foot. You can clean the P15 with a brush and a vacuum cleaner. Also vacuum the dust protection mats in the lids. If the dust protection mats are no longer clean, they must be replaced. In addition, you can remove the effect insert (1) and the shutter slide insert (2) by loosening the knurled screws (3) and sliding the focus carriage towards the lens. Then you can clean the colour filters and CMY panes with a soft cloth and a little window cleaner. To clean the frost flap and zoom/focus unit, remove the four Phillips screws (4) and then the cover. Ensure that you do not bend or damage any parts during cleaning. When cleaning is complete, reconnect the flap, replace the Phillips screws (4) and return the inserts to the unit.

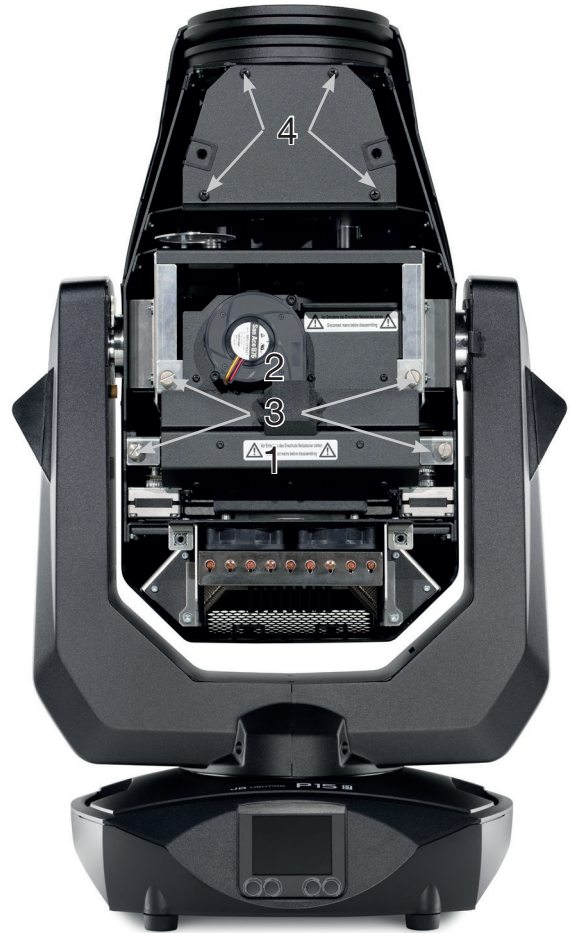

## 8.6 Service and maintenance



**ATTENTION:** Allow the device to cool down and disconnect the device from the mains before opening the device. Touching live parts (high voltage) can give you an electric shock.

### 8.6.1 Inspection of lubricated moving parts

On the P15 Wash, the zoom/focus guide rails and the shutter slide bearings should be checked at regular intervals - minimum once a year - for sufficient lubrication.

To do this, open the head cover (4x camlocks with a half turn) and remove the effect- and shaper modul (2 knurled screws each). It should be noted that the guide rails do not run dry. If necessary, the guide rails must be lightly greased with our special lubricant using a brush. The brass bearings of the individual shutter blades must also be checked for sufficient lubrication and re-oiled/greased if necessary. For the right lubricant, please contact our service.

After the shutter blades bearings, gobos and the rails have been checked and oiled, reinsert the slide-in units. After completing the work, put the head cover back on the fixture and test all functions of the headlight.

## **8.6.2 Checking the plastic parts**

The plastic parts of the P15 Wash should be checked regularly for damage and the onset of cracks. If a plastic part is cracked, do not use this fixture until the damaged part is replaced. Cracks or other damage to the plastic parts can be caused by transport or manipulation by third parties, as well as the aging process can affect plastic materials.

This check is required for both permanent installations and when preparing rental equipment. All damaged plastic parts must be replaced immediately! Defective plastic parts can also lead to further damage in the headlight.

9. Overview of error codes for all fixtures

|                   |   |                 |
|-------------------|---|-----------------|
| PAN TIMEOUT       | Pan   |                 |
| TILT TIMEOUT      | Tilt  |                 |
| GOBO1 TIMEOUT     | Gobo wheel 1 position                           |                 |
| GROT1 TIMEOUT     | Gobo wheel 1 rotation                           |                 |
| GOBO2 TIMEOUT     | Gobo wheel 2 position                           |                 |
| GROT2 TIMEOUT     | Gobo wheel 2 rotation                           |                 |
| COLOR TIMEOUT     | Color wheel                                     |                 |
| CYAN TIMEOUT      | Cyan  |                 |
| MAGENT TIMEOUT    | Magenta   |                 |
| YELLOW TIMEOUT    | Yellow  |                 |
| CTC TIMEOUT       | CTB / CTO                                       |                 |
| IRIS TIMEOUT      | Iris  |                 |
| BLADEROT TIMEOUT  | Blades Rotation                                 |                 |
| BLADE1A TIMEOUT   | Blade1A   |                 |
| BLADE1B TIMEOUT   | Blade1B   |                 |
| BLADE2A TIMEOUT   | Blade2A   |                 |
| BLADE2B TIMEOUT   | Blade2B   |                 |
| BLADE3A TIMEOUT   | Blade3A   |                 |
| BLADE3B TIMEOUT   | Blade3B   |                 |
| BLADE4A TIMEOUT   | Blade4A   |                 |
| BLADE4B TIMEOUT   | Blade4B   |                 |
| ZOOM TIMEOUT      | Zoom  |                 |
| FOCUS TIMEOUT     | Focus   |                 |
| PRISM TIMEOUT     | Prism 1 (linear)                                |                 |
| PRISMROT TIMEOUT  | Prism 1 rotation                                |                 |
| PRISM2 TIMEOUT    | Prism 2 (circular)                              |                 |
| PRISM2ROT TIMEOUT | Prism 2 rotation                                |                 |
| ANI TIMEOUT       | Animation wheel                                 |                 |
| ANIROT TIMEOUT    | Animation wheel rotation                        |                 |
| FAN B1 ER         | Error Fan Base 1                                |                 |
| FAN B2 ER         | Error Fan Base 2                                |                 |
| FAN B3 ER         | Error Fan Base Transformer                      | SPARX ONLY      |
| FAN H1 ER         | Error Fan Head 1                                |                 |
| FAN H2 ER         | Error Fan Head 2                                |                 |
| FAN H3 ER         | Error Fan Head 3                                |                 |
| FAN H4 ER         | Error Fan Head 4                                |                 |
| FAN H5 ER         | Error Fan Head 5                                |                 |
| FAN H6 ER         | Error Fan Head 6                                |                 |
| FAN H7 ER         | Fan Blades (P18)<br>Fan for Effekt modul motors | only P15 series |
| FAN H8 ER         | Fan for Effekt modul motors                     | only P15 series |
| FAN H9 ER         | Fan Blades, on the blade module                 | only P15 series |

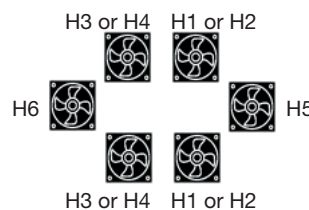
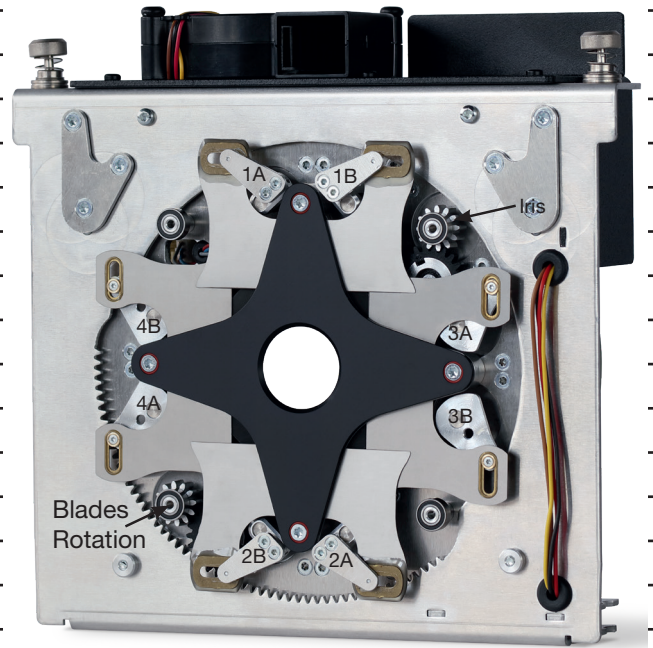

|                     |   |            |
|---------------------|---|------------|
| TSENS BPS ER        | Sensor Error Base Power Supply AC/DC                  |            |
| TSENS BLCD ER       | Sensor Error Base LCD                                 |            |
| TSENS BAIR ER       | Sensor Error Base Air                                 | SPARX ONLY |
| TSENS HMAIN ER      | Sensor Error Head Main PCB                            |            |
| TSENS HDRV ER       | Sensor Error Head LED Driver PCB                      |            |
| TSENS HLED ER       | Sensor Error Head LED                                 |            |
| TSENS HAIR ER       | Sensor Error Head Air (Ambient)                       |            |
| HIGH TEMP BLCD      | High Temperature Base LCD PCB                         |            |
| HIGH TEMP BAIR      | High Temperature Base Air (SPARX ONLY)                |            |
| HIGH TEMP BPS       | High Temperature Base PSU AC/DC                       |            |
| HIGH TEMP HMAIN     | High Temperature Head Main PCB                        |            |
| HIGH TMP HDRV       | High Temperature Head LED Driver PCB                  |            |
| HIGH TMP H LED      | High Temperature Head LED Module                      |            |
| HIGH TEMP HEAD AIR  | High Temperature Head Air (Ambient)                   |            |
| CPU1 NOT RESPONDING | CPU Display PCB                                       |            |
| CPU2 NOT RESPONDING | CPU Pan/Tilt PCB                                      |            |
| CPU3 NOT RESPONDING | CPU Main Head PCB                                     |            |
| CPU4 NOT RESPONDING | CPU Main Head PCB: MK2 MAIN HEAD, P15 CMY, MK1 BLADES |            |
| CPU5 NOT RESPONDING | CPU Blades PCB: MK1 LED DRIVER PCB                    |            |
| CPU6 NOT RESPONDING | CPU LED Driver PCB: MK1 N.A.                          |            |

If one or both slots in the headlight are missing or not plugged in correctly, "BUS" will be shown on the display to inform you that one or both slots are missing.

## 10. JB-Lighting user network

Do you want to rent out your JB-Lighting products or rent additional ones?

Then join our User Network! Become part of our JB Community!

Other members can easily filter by location or postal code, distance, and the JB product they need – allowing them to rent your offered moving heads. Let's go!

Here you can find our user network:

[https://www.jb-lighting.de/JBUserNetwork?utm\\_source=handbuch&utm\\_medium=print&utm\\_campaign=qr\\_code\\_handbuch](https://www.jb-lighting.de/JBUserNetwork?utm_source=handbuch&utm_medium=print&utm_campaign=qr_code_handbuch)



## 11. Specifications

### Dimensions and weight

|                      |        |
|----------------------|--------|
| Length . . . . .     | 264 mm |
| Width . . . . .      | 421 mm |
| Height . . . . .     | 682 mm |
| Net weight . . . . . | 23 kg  |

### Electronic system

|  |                       |
|--|-----------------------|
| Mains connection . . . . .             | 100-240 V AC, 50-60Hz |
| Maximum power consumption . . . . .    | 1100 VA               |
| Power consumption in standby . . . . . | 100 VA                |

### Temperature

|                                       |       |
|---------------------------------------|-------|
| Maximum ambient temperature . . . . . | 45 °C |
| Minimum ambient temperature . . . . . | 0 °C  |

### Optics, Photometric Data

|                            |                               |
|----------------------------|-------------------------------|
| Light source . . . . .     | White light LED module 1000 W |
| Luminous flux HP . . . . . | 34000 Lumen @ 20°C            |
| Luminous flux HC . . . . . | 22000 Lumen @ 20°C            |
| Luminous flux WW . . . . . | 19000 Lumen @ 20°C            |

### Effects

|                |          |
|----------------|----------|
| Pan . . . . .  | 546.74°  |
| Tilt . . . . . | 281.16°  |
| Zoom . . . . . | 9° - 66° |

### Construction

|                              |        |
|------------------------------|--------|
| Colour . . . . .             | black  |
| Housing . . . . .            | PC ABS |
| Protection class . . . . .   | IP 20  |
| Plug-in technology . . . . . | yes    |

### Installation

|   |                   |
|---|-------------------|
| Installation site . . . . .   | indoor            |
| Holder . . . . .  | 2x Omega brackets |
| Position . . . . .  | any               |
| Minimum fixture distance to flammable objects . . . . .                                 | 1.0 m             |
| Minimum distance between the light emission and the surface to be illuminated . . . . . | 4.0 m             |

### Connections

|                                       |                        |
|---------------------------------------|------------------------|
| Power input . . . . .                 | Neutrik powerCON TRUE1 |
| Power feed-through . . . . .          | Neutrik powerCON TRUE1 |
| DMX/RDM in/out USITT DMX512 . . . . . | 5-pin, in/out XLR      |
| Ethernet in/out . . . . .             | Neutrik etherCON       |
| Micro-USB . . . . .                   | Software update        |









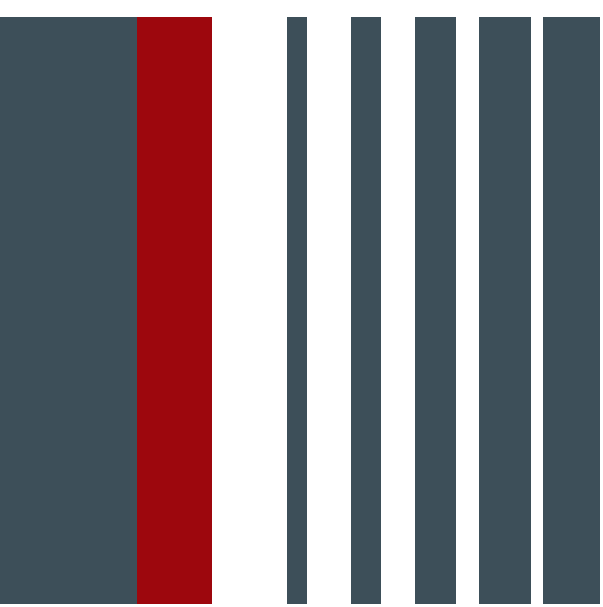

JB-Lighting Lichtanlagentechnik GmbH  
Sallersteig 15  
89134 Blaustein  
Tel. +49 7304 9617-0  
Fax. +49 7304 9617-99  
info@jb-lighting.de  
www.jb-lighting.de

**JB LIGHTING**